



What is Railways? **An introduction to the Railway System ...for beginners...**

Kostas Tzanakakis

February 2019

railhow.com



What is this presentation about?

- General presentation of the railway system, targeting beginners with no railway experience.
- We will examine the railway system from the points of view of the various Stakeholders:
 - the cities,
 - the passengers who are using the trains,
 - the Infrastructure Managers who are managing the railway infrastructure,
 - the Train Operators who are running trains and finally
 - the providers of Rolling Stock (the trains).



**....this is the age
of the train....**

We examine the railway system from different points of view....

City's
point of view



Passenger's
point of view



Operator's
point of view

Rolling Stock
Provider's
point of view

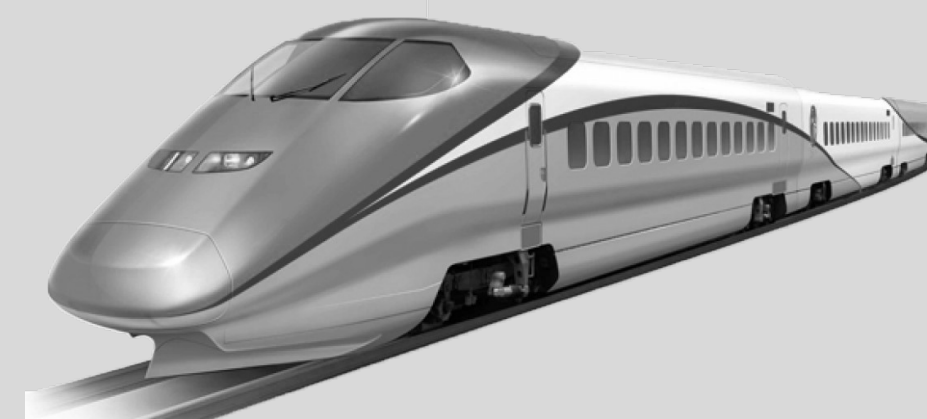

Infrastructure
Manager's
point of view



point of view



The Railway Station and the City



Landmark for the City.....

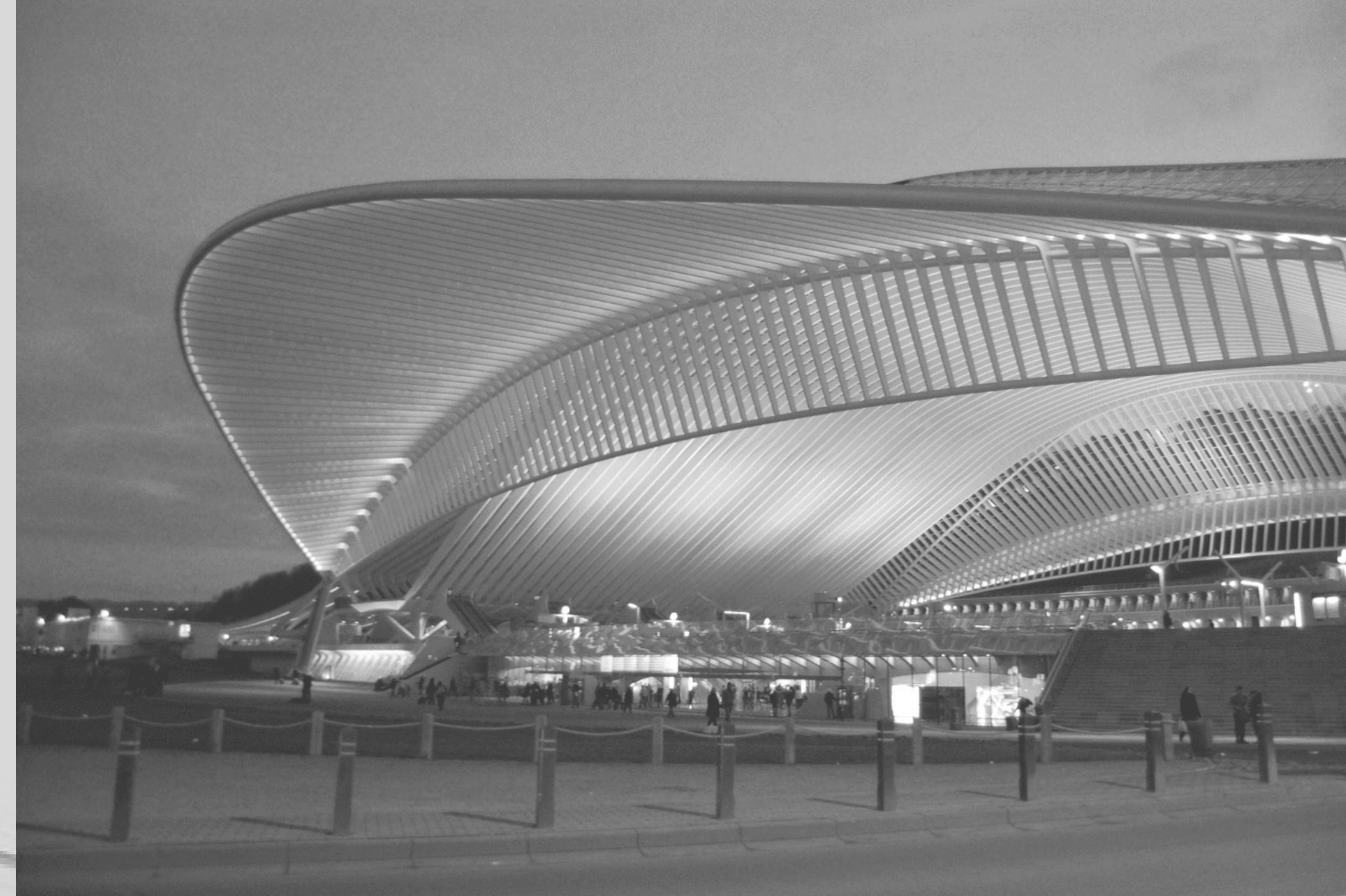

Integration to the city - intermodality....





Before / after the travel



Getting travel information / Buying a ticket

Selection single ride

Station/Stop	Date	Time	Duration	Chg.	Products	Standard fare
Frankfurt(M) Flughafen Fernbf Karlsruhe Hbf	Sa, 03.03.12	dep 14:54 arr 15:58	1:04	1	ICE 	38,00 EUR
Frankfurt(M) Flughafen Fernbf Karlsruhe Hbf	Sa, 03.03.12	dep 15:54 arr 16:58	1:04	0	ICE	38,00 EUR
Frankfurt(M) Flughafen Fernbf Karlsruhe Hbf	Sa, 03.03.12	dep 16:54 arr 17:58	1:04	1	ICE	38,00 EUR
Frankfurt(M) Flughafen Fernbf Karlsruhe Hbf	Sa, 03.03.12	dep 17:54 arr 18:58	1:04	0	ICE	38,00 EUR
Frankfurt(M) Flughafen Fernbf Karlsruhe Hbf	Sa, 03.03.12	dep 18:54 arr 19:58	1:04	1	ICE	38,00 EUR
Frankfurt(M) Flughafen Fernbf Karlsruhe Hbf	Sa, 03.03.12	dep 19:54 arr 21:00	1:06	0	ICE	38,00 EUR
Frankfurt(M) Flughafen Fernbf Karlsruhe Hbf	Sa, 03.03.12	dep 20:54 arr 21:58	1:04	1	ICE	38,00 EUR
Frankfurt(M) Flughafen Fernbf Karlsruhe Hbf	Sa, 03.03.12	dep 21:54 arr 23:00	1:06	0	ICE	38,00 EUR
Frankfurt(M) Flughafen Fernbf Karlsruhe Hbf	Sa, 03.03.12 Su, 04.03.12	dep 23:04 arr 00:13	1:09	1	ICE	38,00 EUR

1 adult, 2nd class

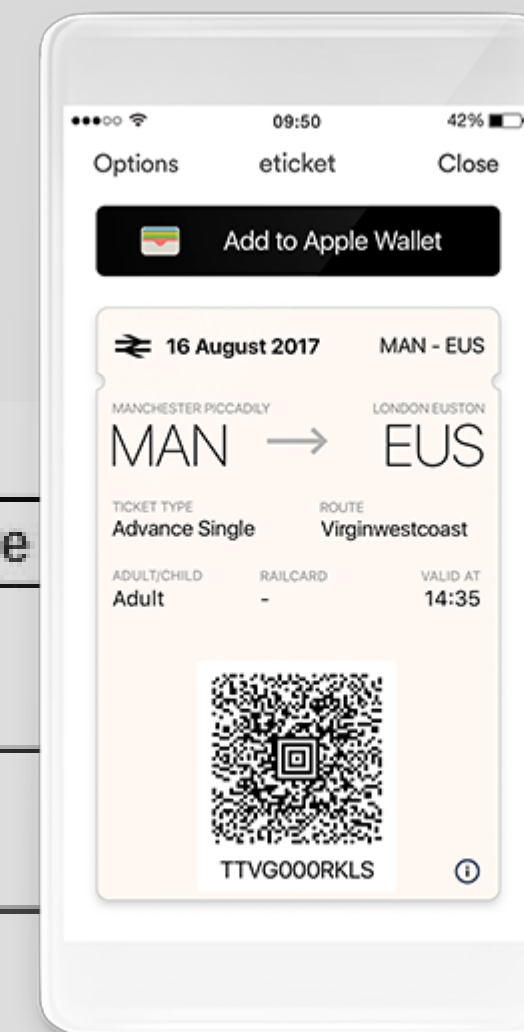

Arriving at the station



Car

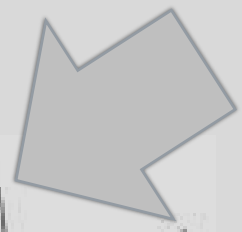

Metro



Taxi



Bus

The Railway station: Start of a travel experience



Getting Info: Passenger Information System (PIS)



Waiting





Shopping.....



Travelling (in the train...)

With the train you are not “transported” you are travelling!!!



Passenger trains for travellers





20

2A 2C

12





Business travelers



Operator's

point of view



Railway Services offered by Carriers
(Railway Undertakings / Operators)



Types of trains for Passengers

Light Rail or Light Rail Transit (LRT)

- Light rail or light rail transit (LRT) is a form of urban rail public transportation that generally has a lower capacity and lower speed than heavy rail and metro systems, but higher capacity and higher speed than street-running tram systems.



Commuter / suburban rail services

- Commuter trains, also called suburban trains, is a passenger rail transport service that primarily operates between a city centre, and the middle to outer suburbs



Regional / local rail services

- Regional trains, also known as local trains are passenger train services that operate between towns and cities. These trains operate with more stops over shorter distances than inter-city rail, but fewer stops and faster service than commuter rail.



Inter-city rail services

- Inter-city rail services are express passenger train services that cover longer distances than commuter or regional trains.



Night Train

- A special service for connecting cities over long distance (500-800 km) is the Night Train, a train that runs at night.
- The train has sleeping cars, offering the possibility for the passenger to travel overnight providing full “hotel services” and to arrive in the morning at his destination.
- There is also a possibility to have also the private car on the same train.





Sleeping car (luxury compartment)



High speed rail services

- The High Speed system today includes trains running at speeds between 220 km/h and 350 km/h. This range of speeds continues to increase as technology provides solutions for increasing the maximum levels.



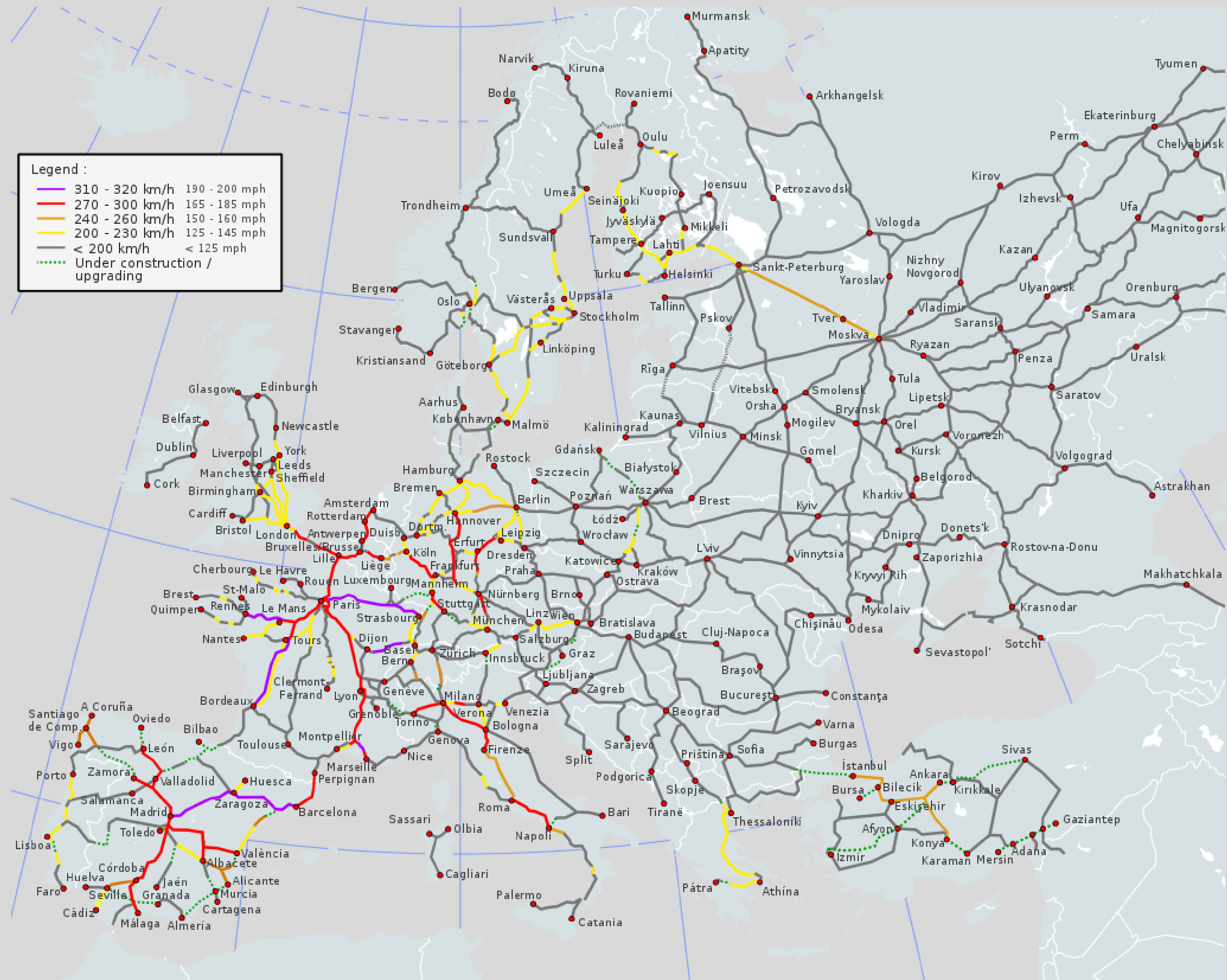

The planned high speed railway network in Europe (2017)

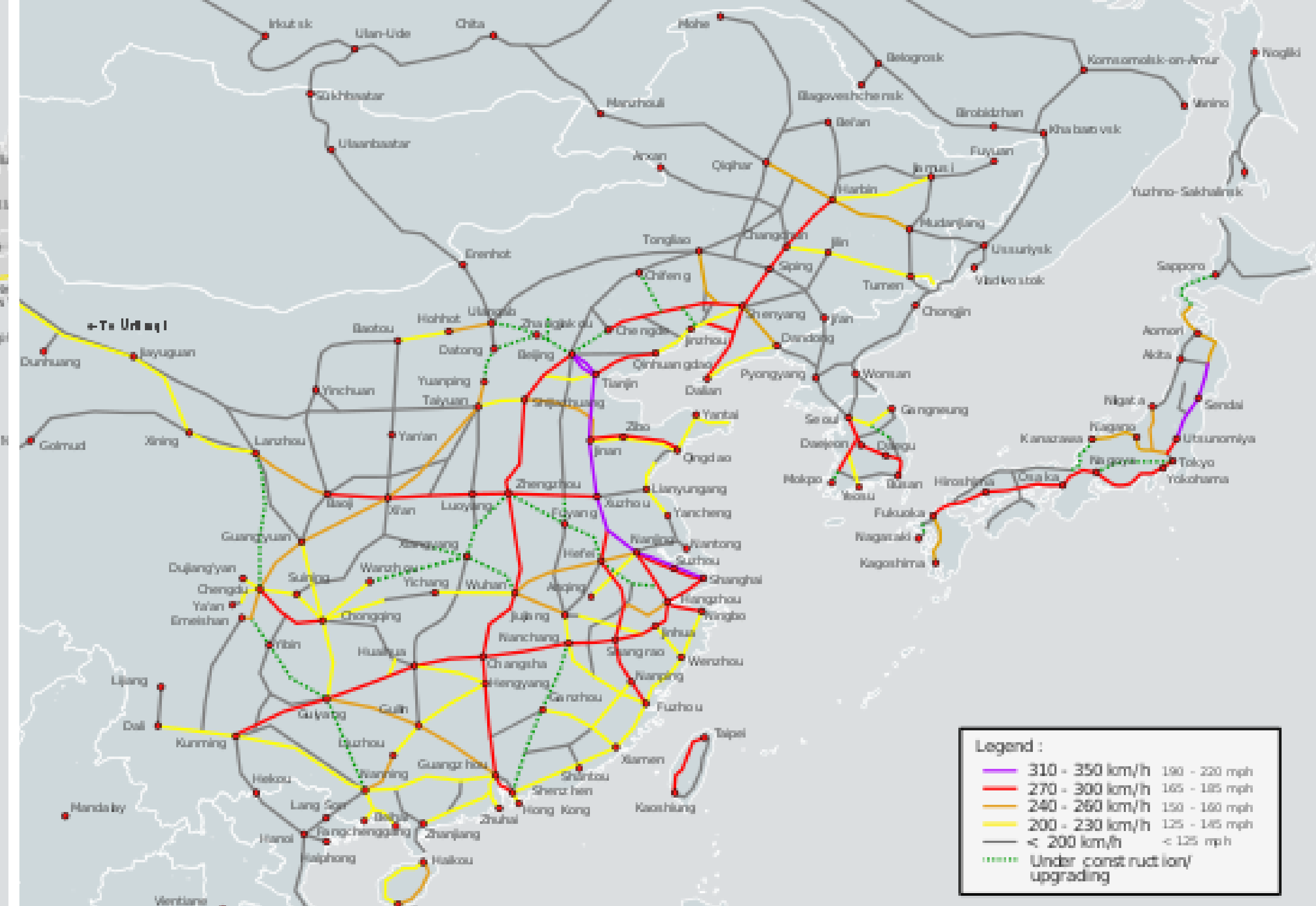
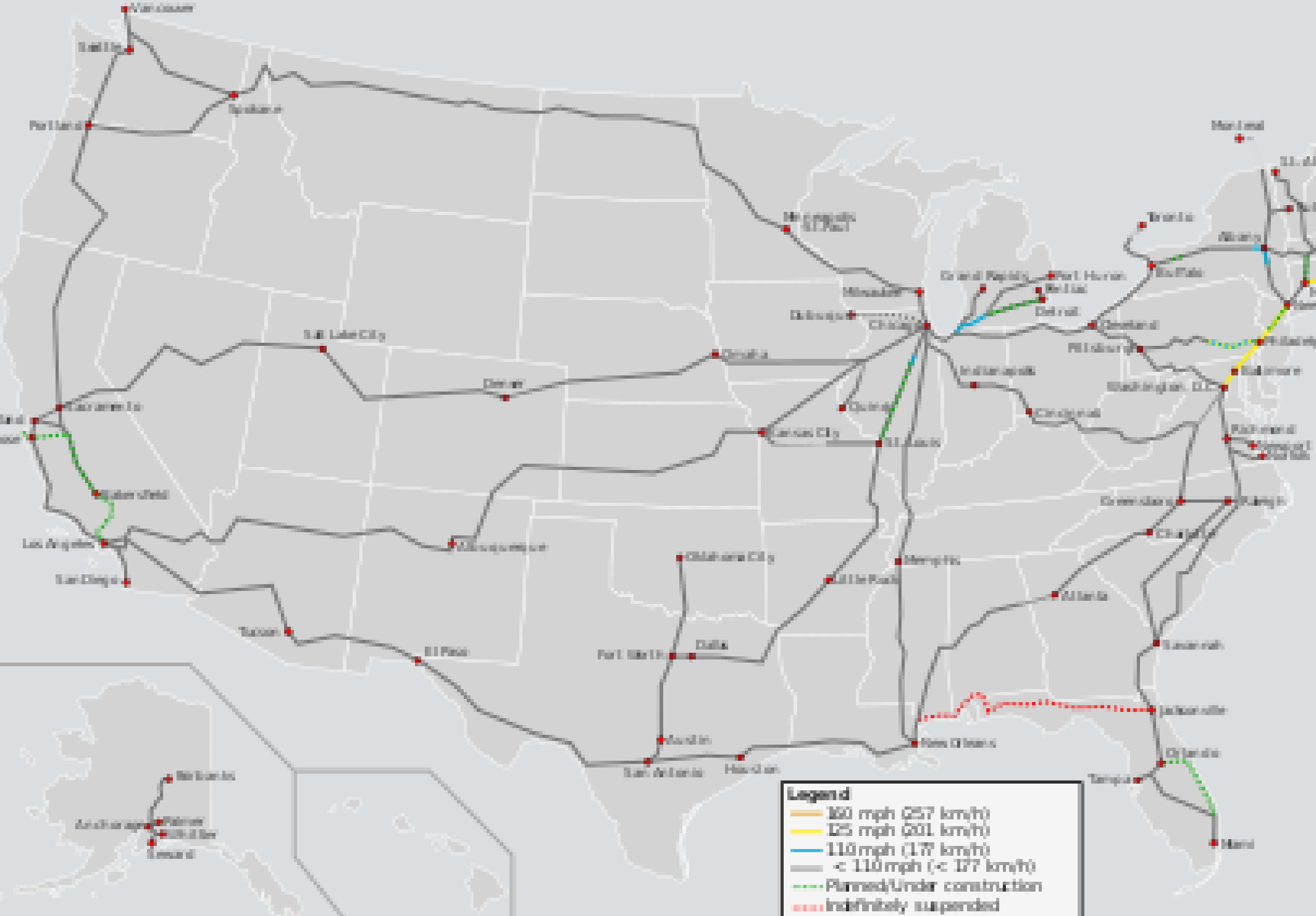

High-speed rail in the USA and East Asia

Questions / Discussion

1. What is world record with trains on conventional lines?
2. High speed rail vs. airplane: what is faster?

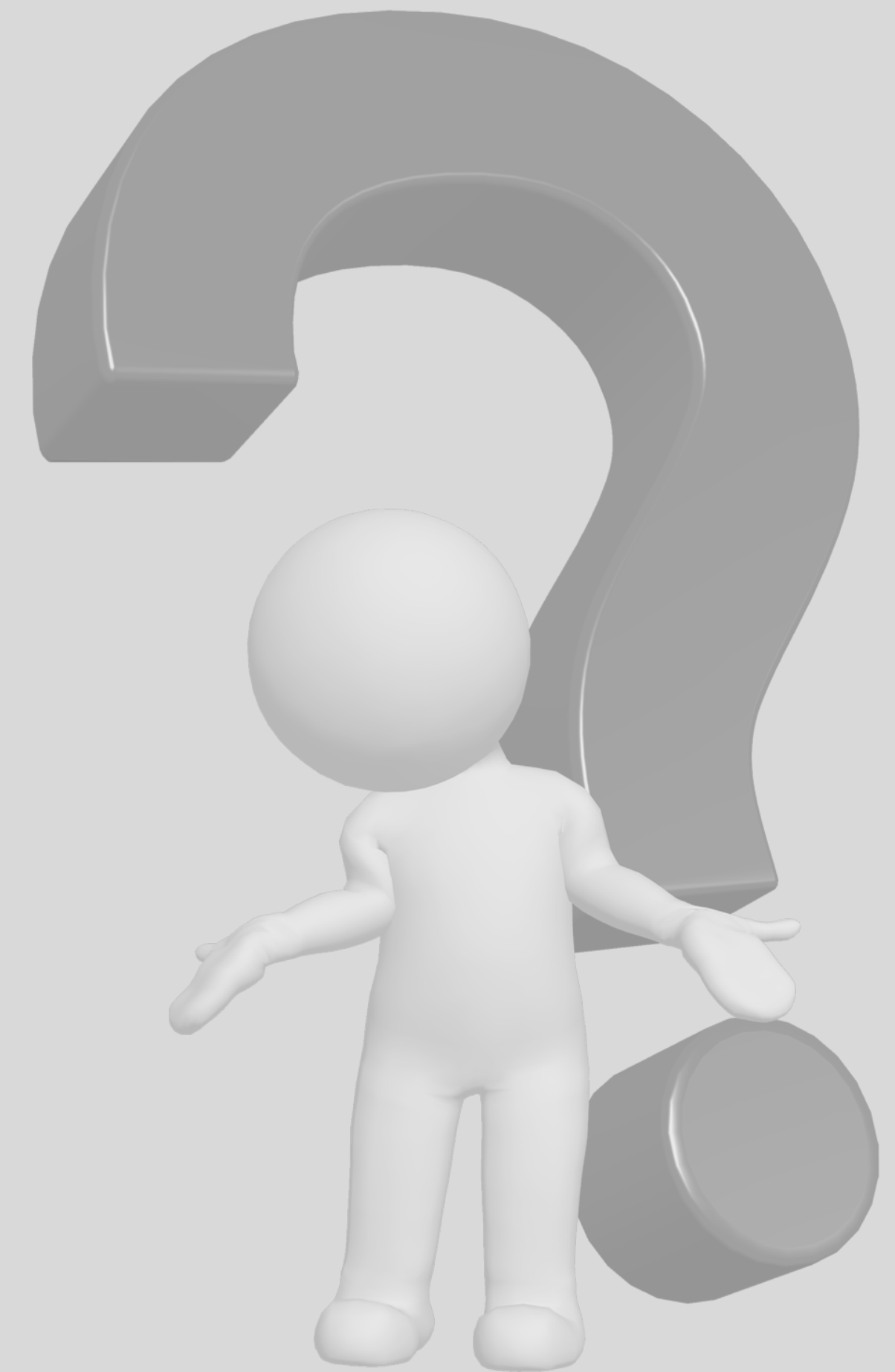

Answers

1. What is world record with trains on conventional lines?

April 2007, reaching 574.8 km/h



VIDEO

2. High speed rail vs. airplane: what is faster

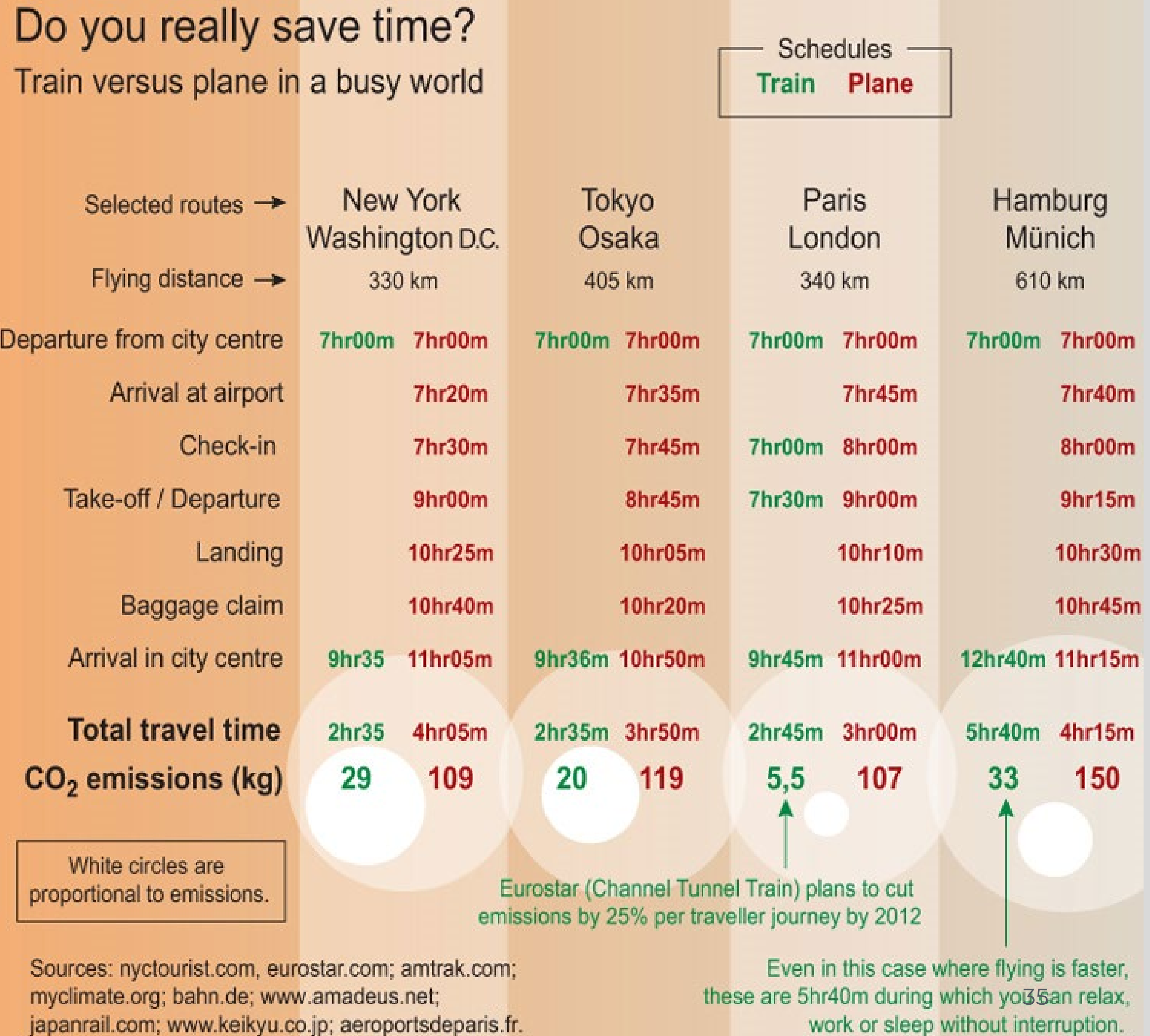
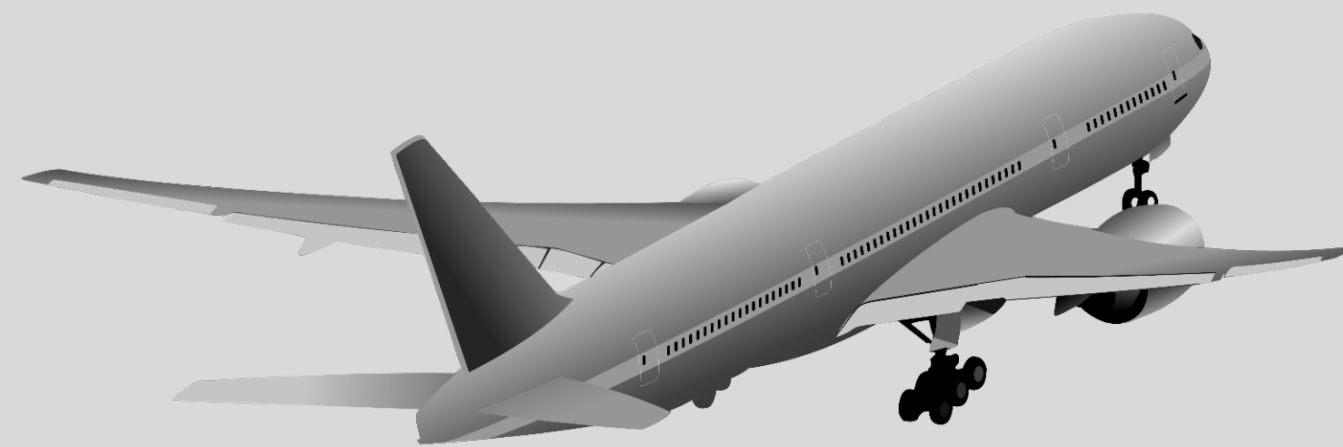
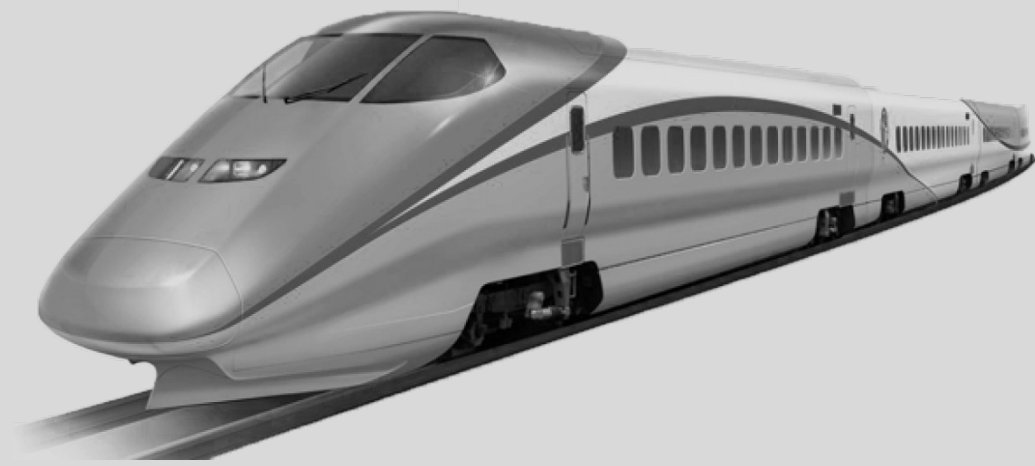

- Till distance of ≈ 140 km conventional train is faster than high speed train
- Till distance of ≈ 400 km conventional train is faster than plane
- Till distance of ≈ 900 km high speed train is faster than plane
- For distances >900 km, plane is faster.

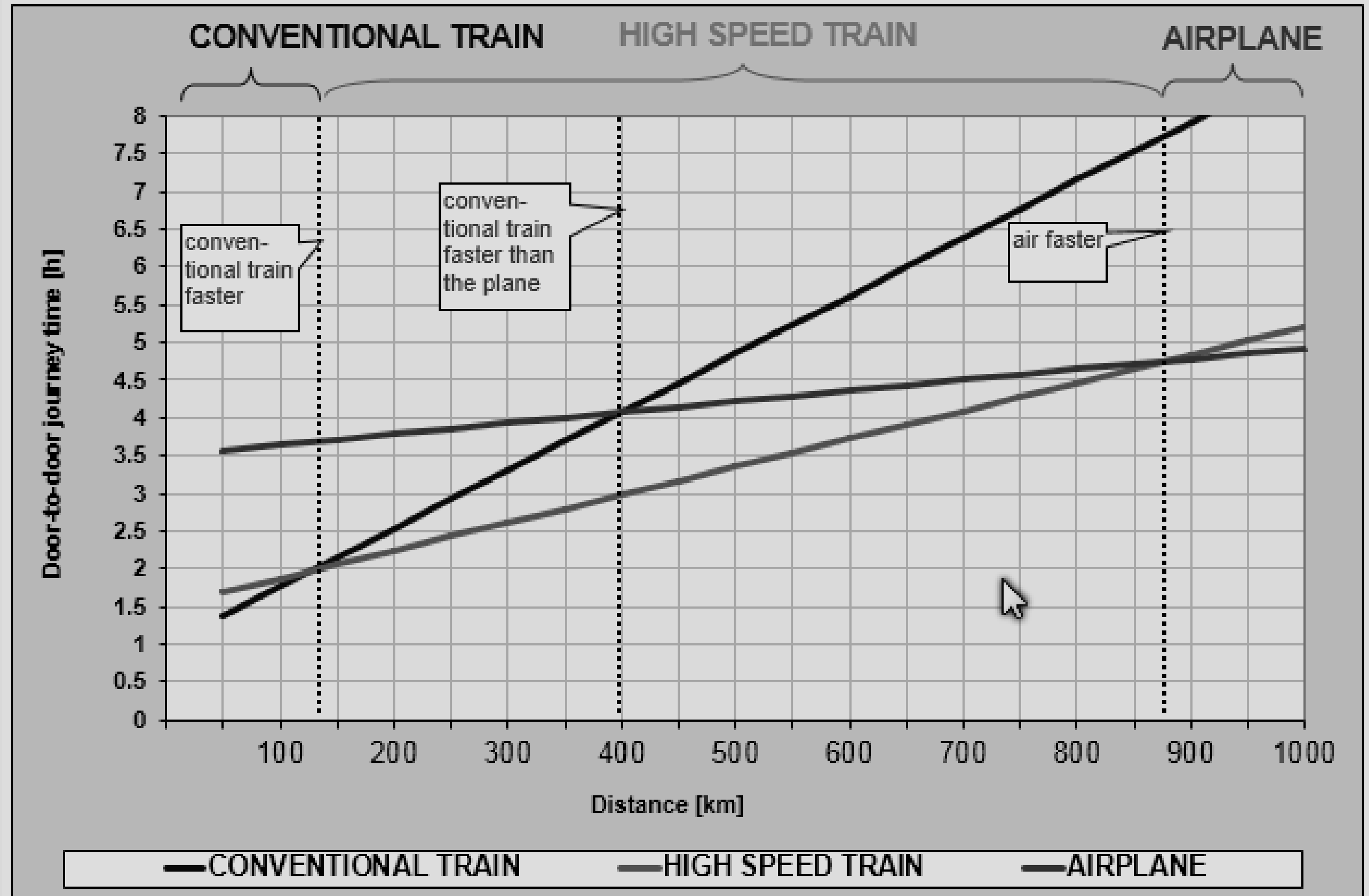

Travel time and market share

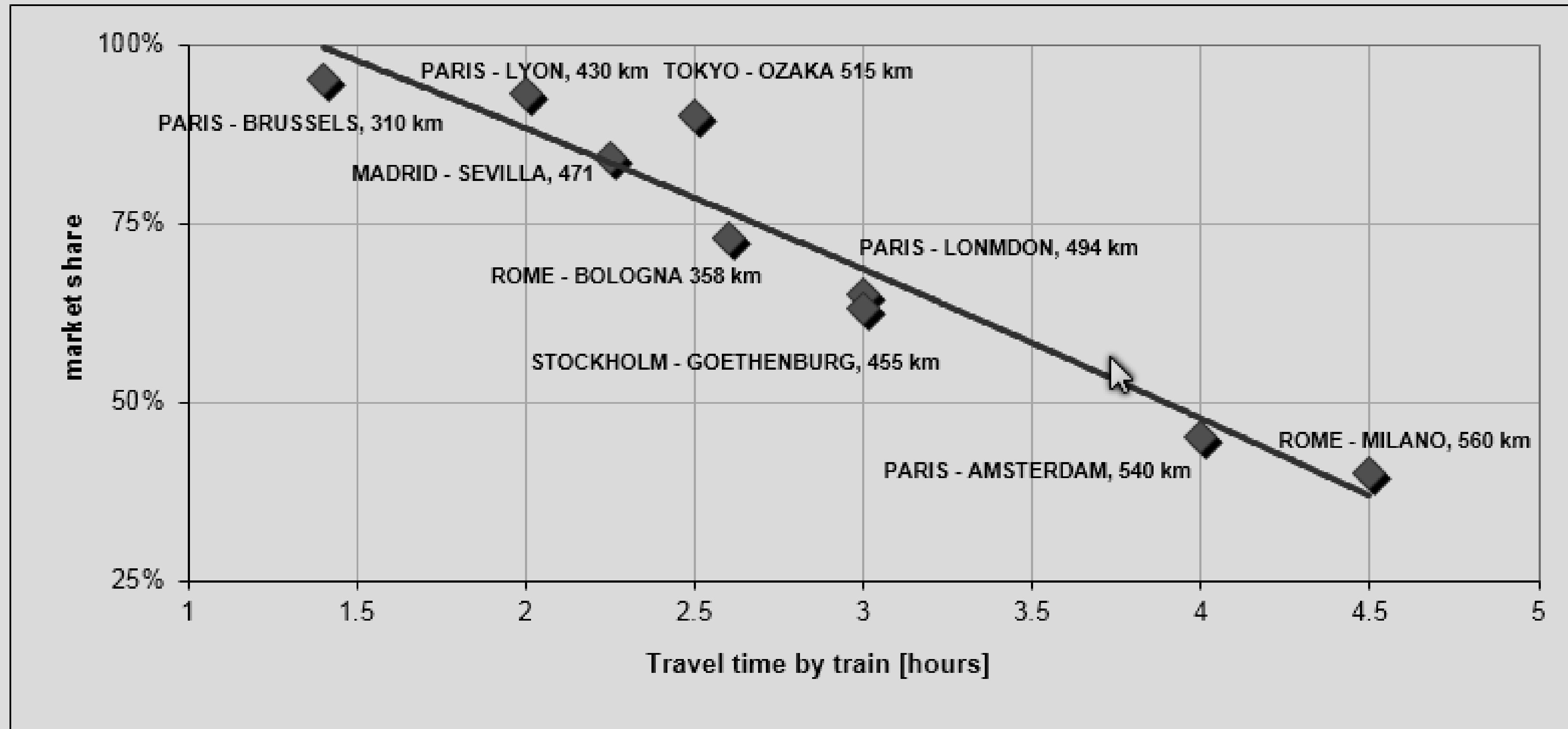



CARGO
CONTAINER

**Moving
goods....**

Freight (Cargo) Trains



VIDEO



Intermodal freight transport

- Intermodal freight transport involves the transportation of freight in an intermodal container or vehicle, using multiple modes of transportation (e.g., rail, ship, and truck), without any handling of the freight itself when changing modes.



Trucks on trains “Rolling Motorway”

- The rolling highway is a special form of combined transport in which full trucks are transported on special rail cars, generally accompanied by the truck drivers, who travel in a passenger car.



An amazing freight train: The Tehachapi loop!



The Tehachapi Loop is a 1.17 km long 'spiral', on the Union Pacific Railroad line through Tehachapi Pass, of the Tehachapi Mountains in south-central California.

Seeing a daily average of almost 40 trains, the line is one of the busiest single-track mainlines in the world.

On the loop, the track passes over itself, lessening the grade. The loop gains 23 m in elevation as the track climbs at a steady 2% grade. A train more than 1,200 m long thus passes over itself going around the loop.

[Video](#)



Infrastructure Manager's

point of view

**The Railway Infrastructure Manager:
keep railway infrastructure safe and
operational, manage the traffic...**



The Railway Infrastructure

Infrastructure

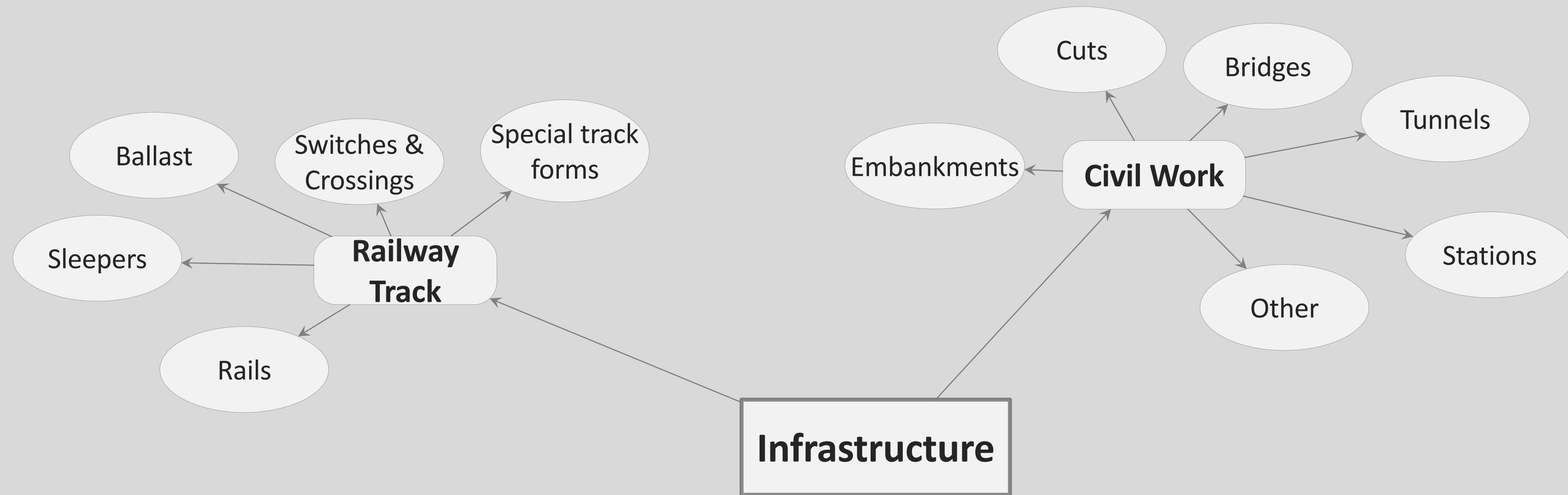

The railway track

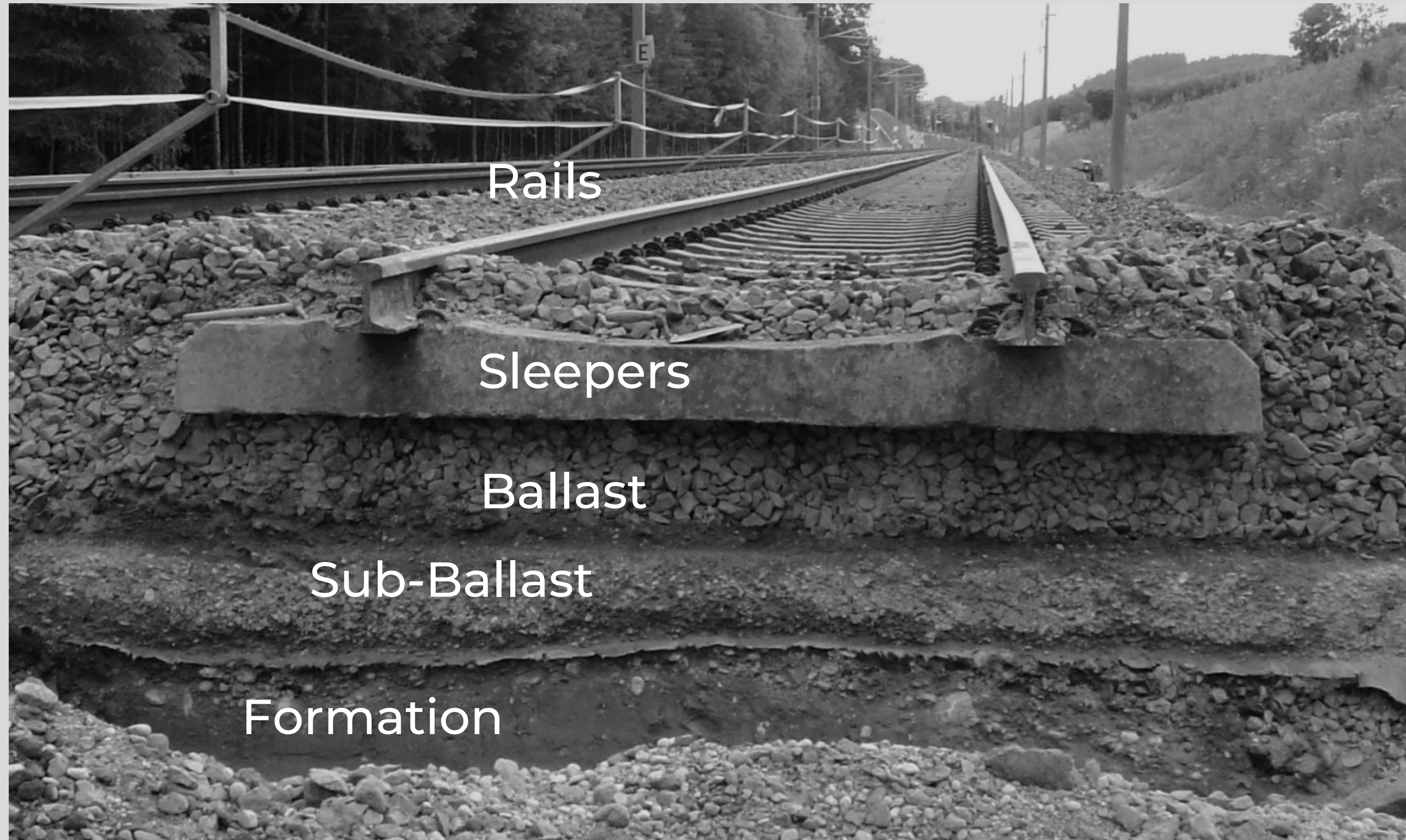

- Rails
- Sleepers
- Ballast, sub-ballast, formation

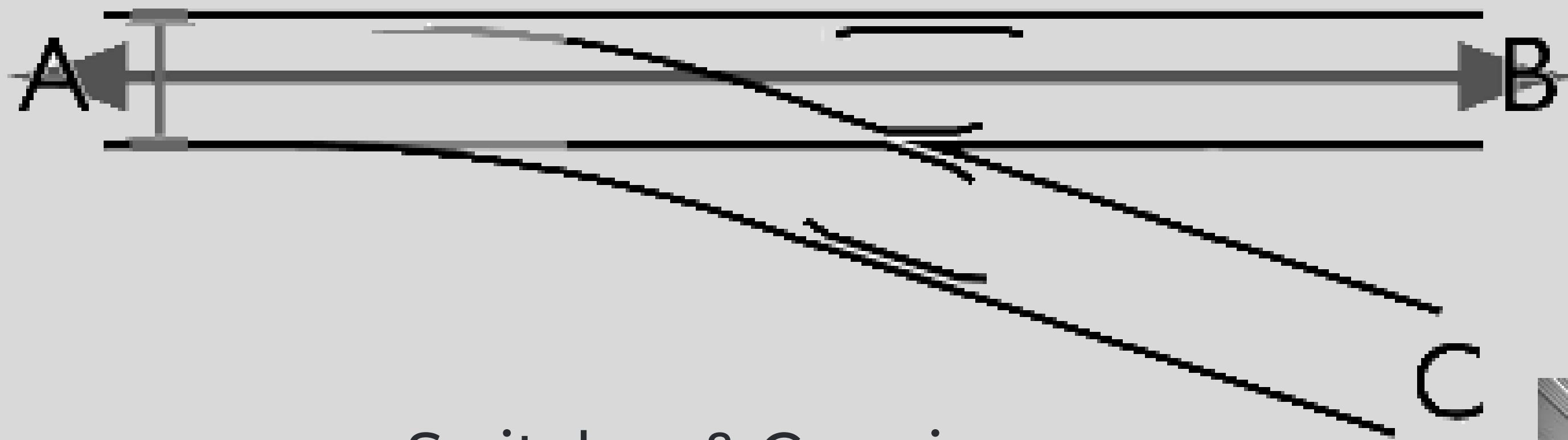

Switches & Crossings



Special track forms in Depot Areas

Civil work

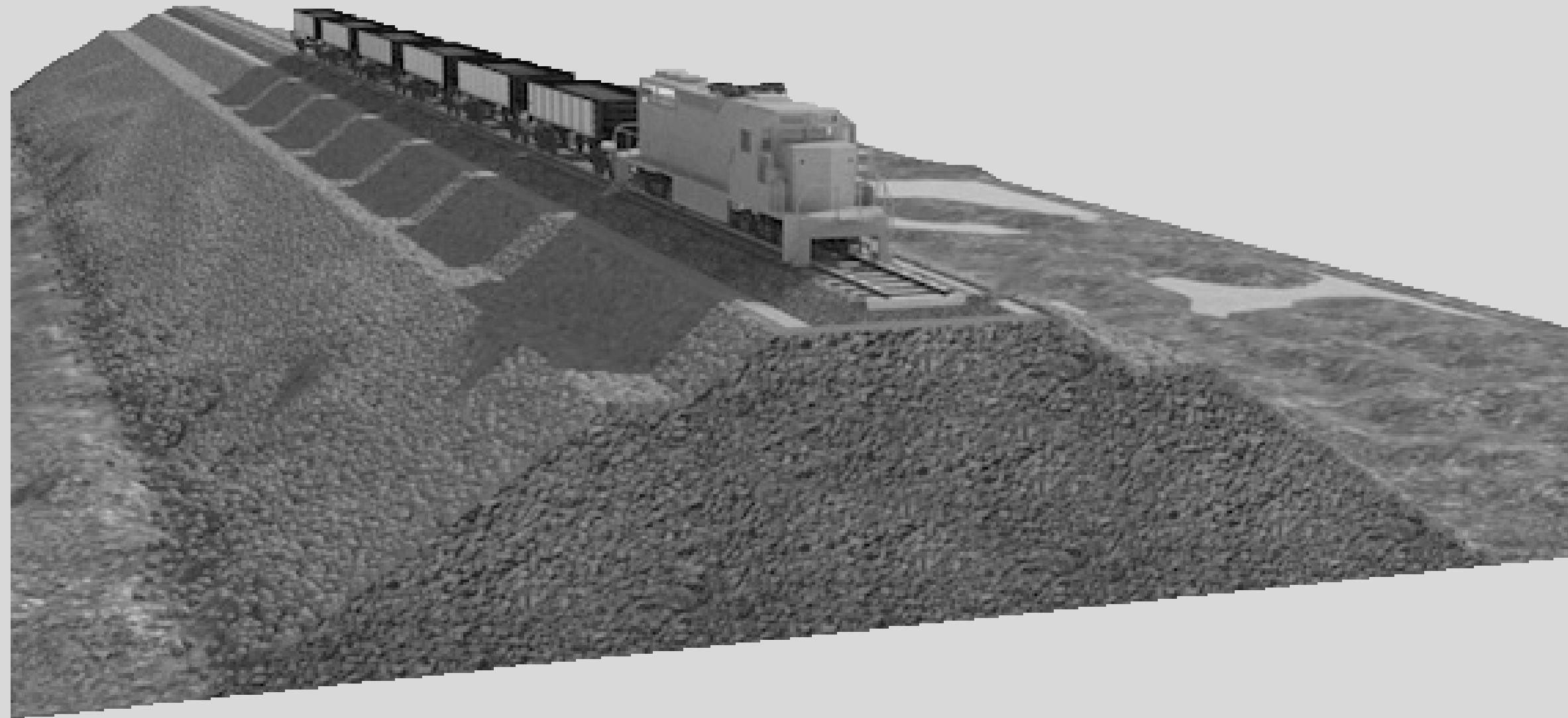

Embankment

Cut





Bridges



Tunnels



Railway stations



Overpasses

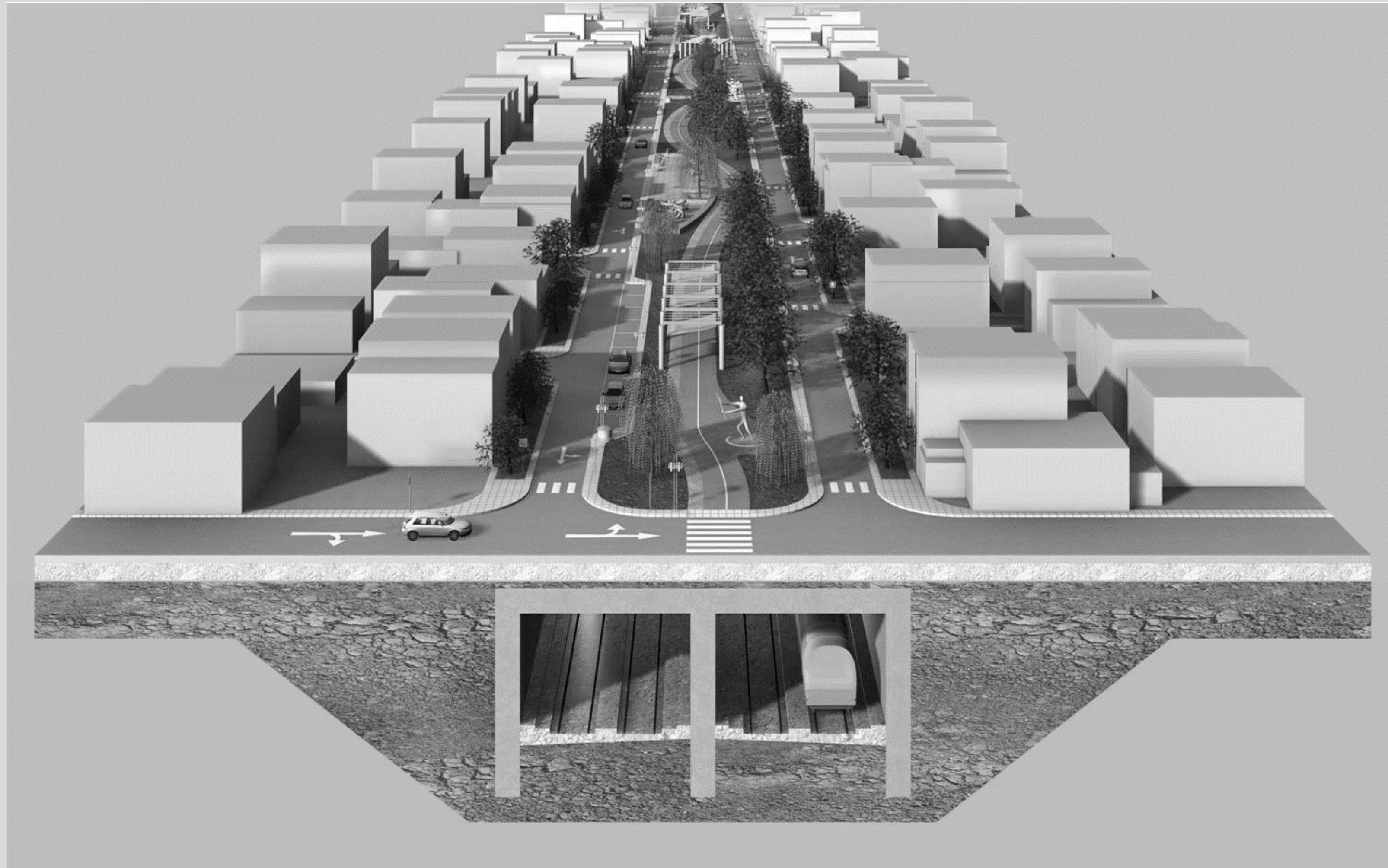

Underground railway lines in urban areas

B. Technological systems

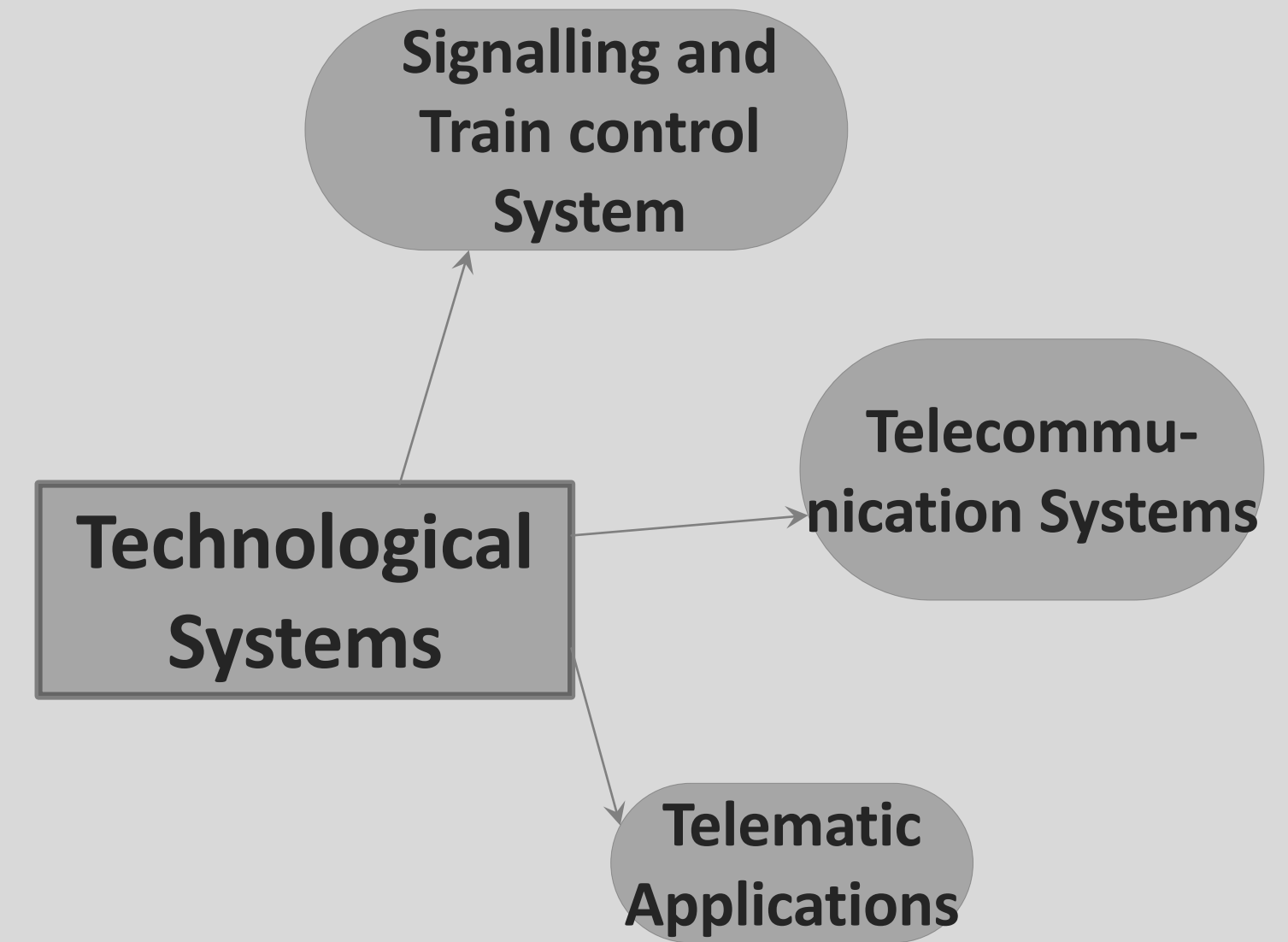
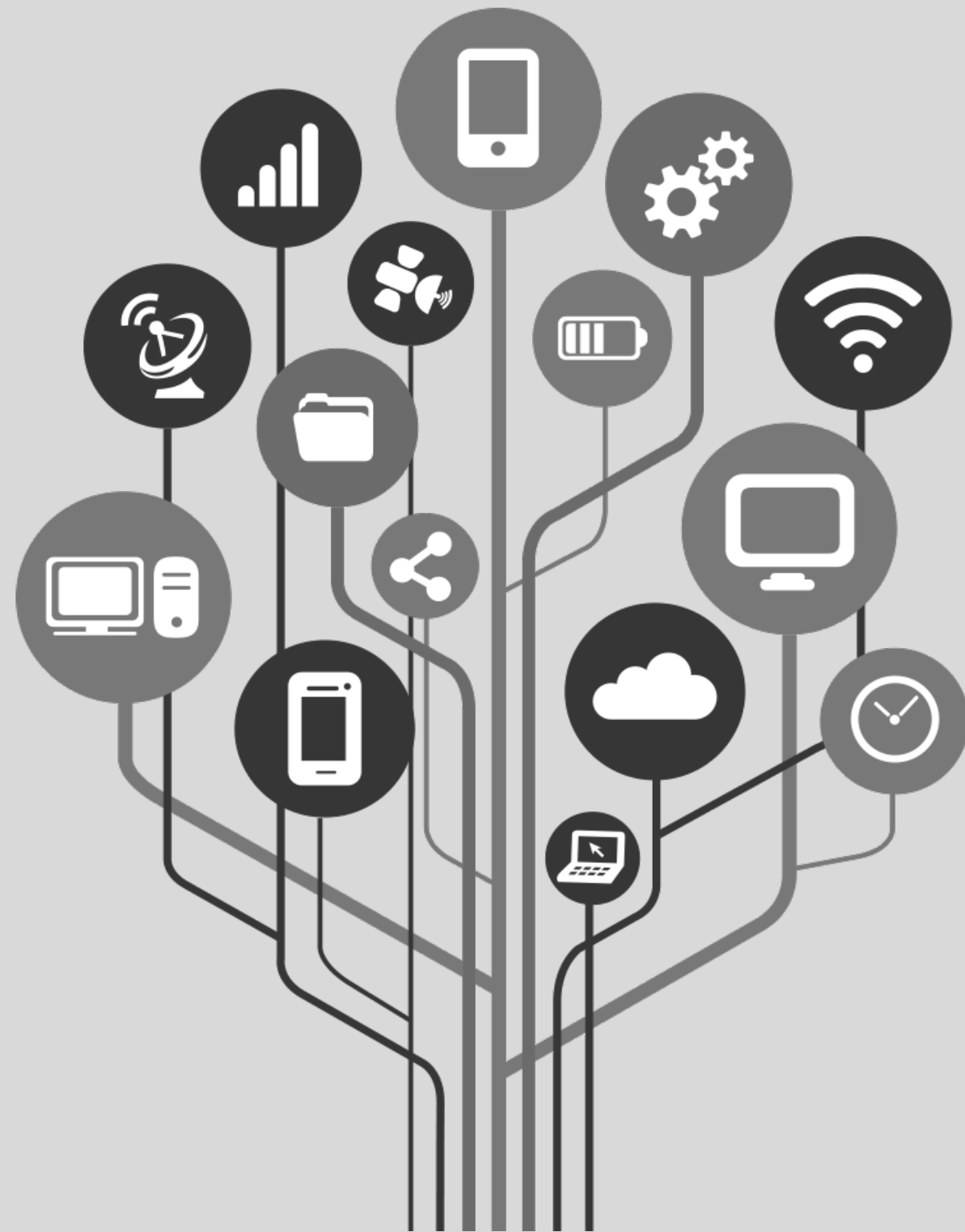

B1. Signalling and Train Control System



Centralised Traffic Control

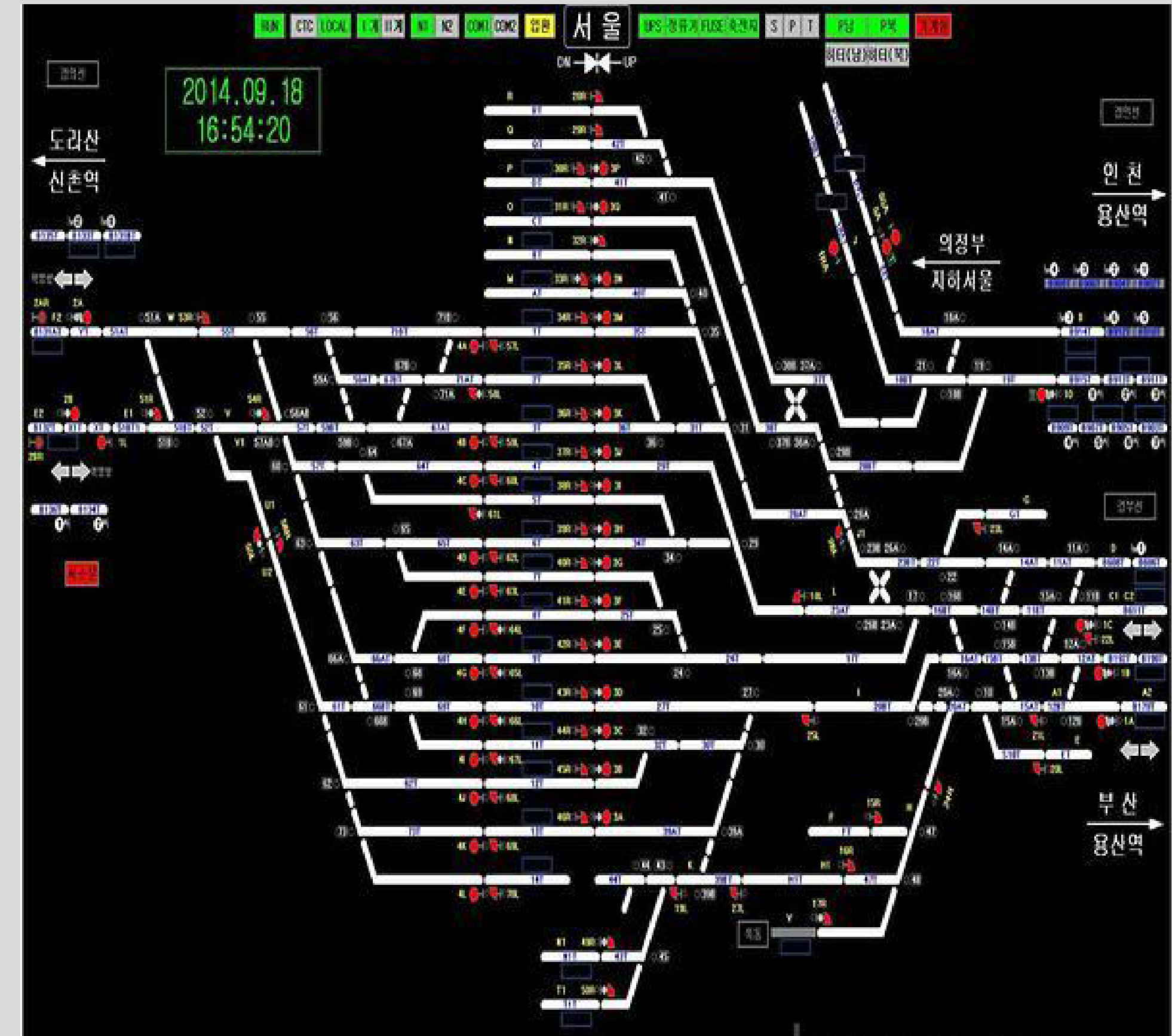

Computer Based Interlocking



Automatic Train Control and Train Protection

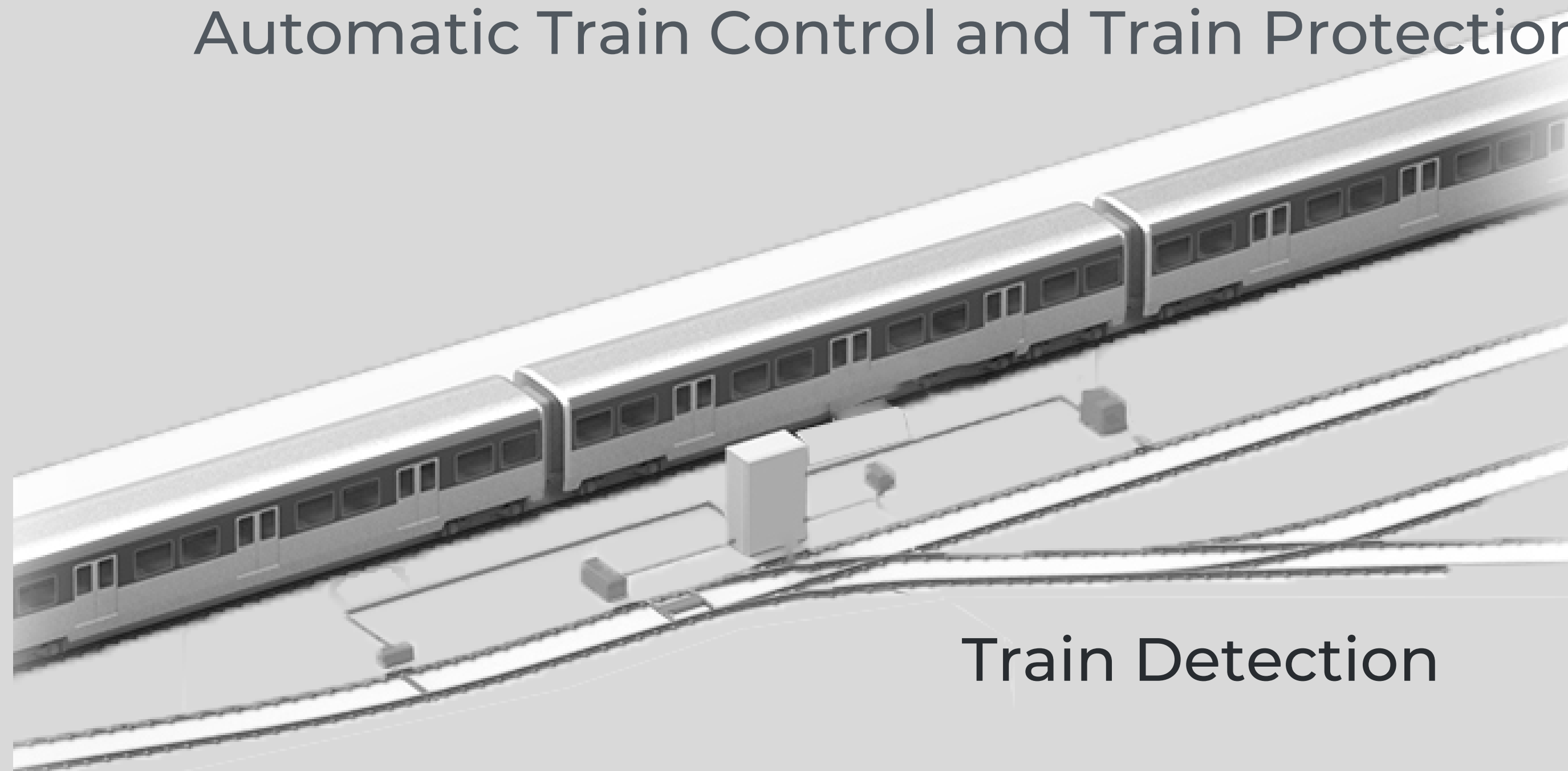

Train Detection

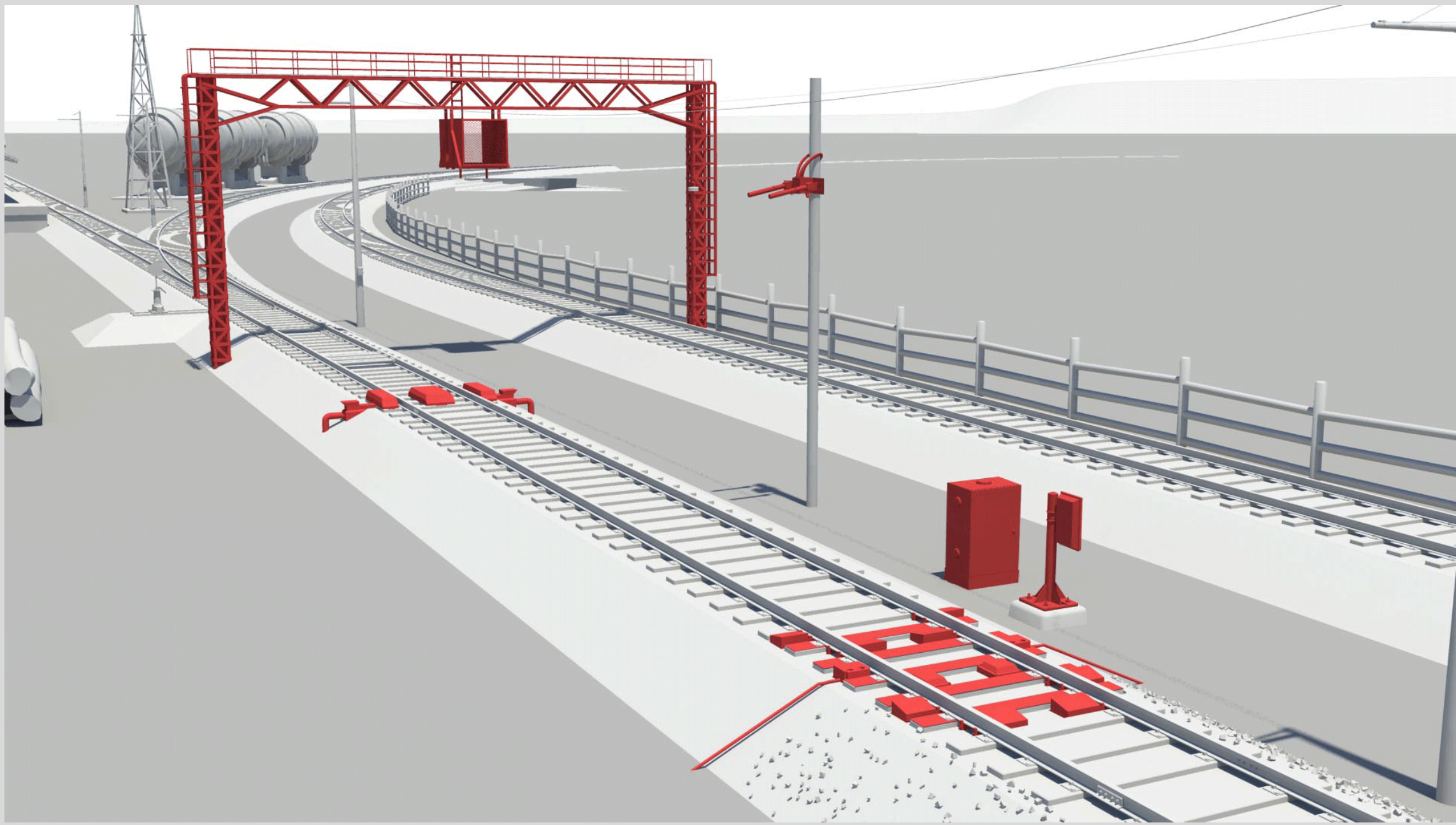

Trackside Devices



Auxiliary Defect Detectors



Telecommunication systems

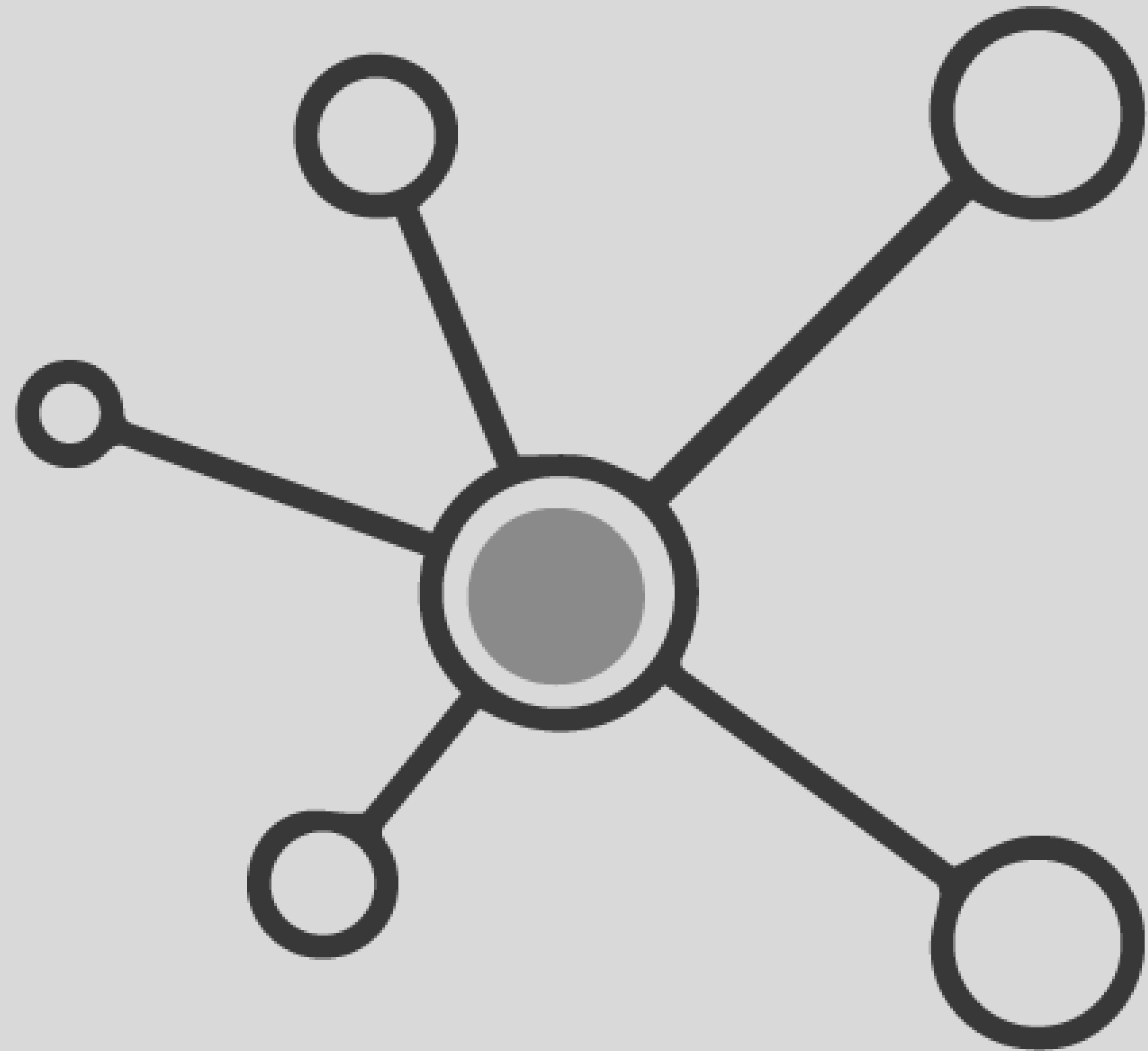

Communications systems include:

- Multi-Service Network (CCNN) and Fibre Optic Network (FON)
- Local Area Networks



Telephone System



Help Points



Public Address System



Master Clock

Telematics applications

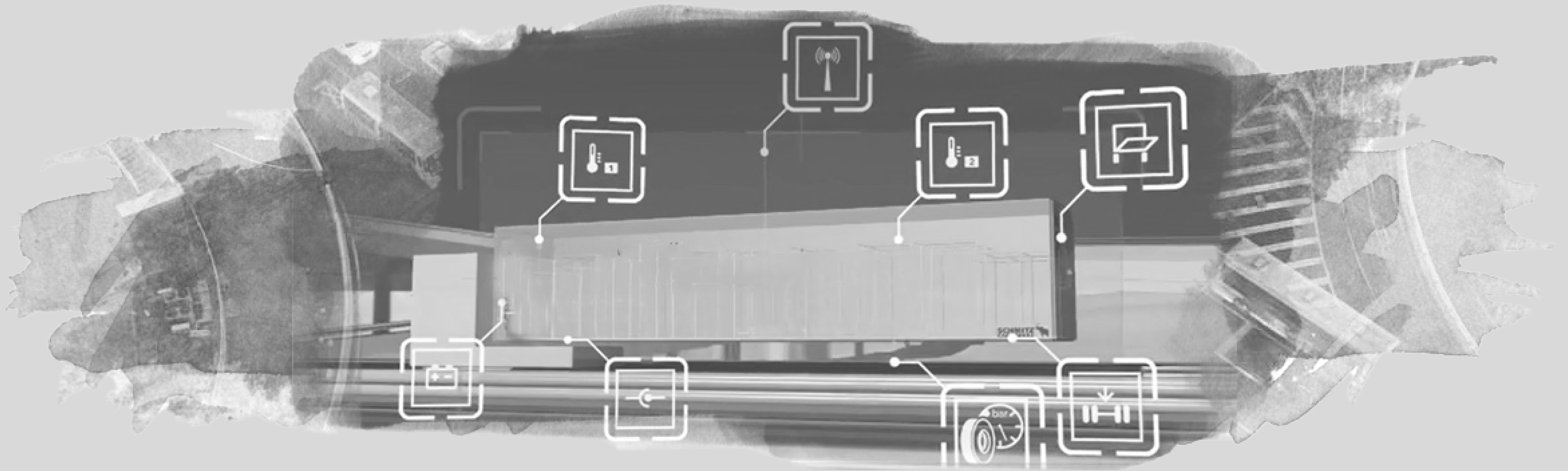

This subsystem comprises two elements:

- applications for passenger services
- applications for freight services



Safety & security systems



- Fire detection / alarm Systems
- Fire Fighting Systems

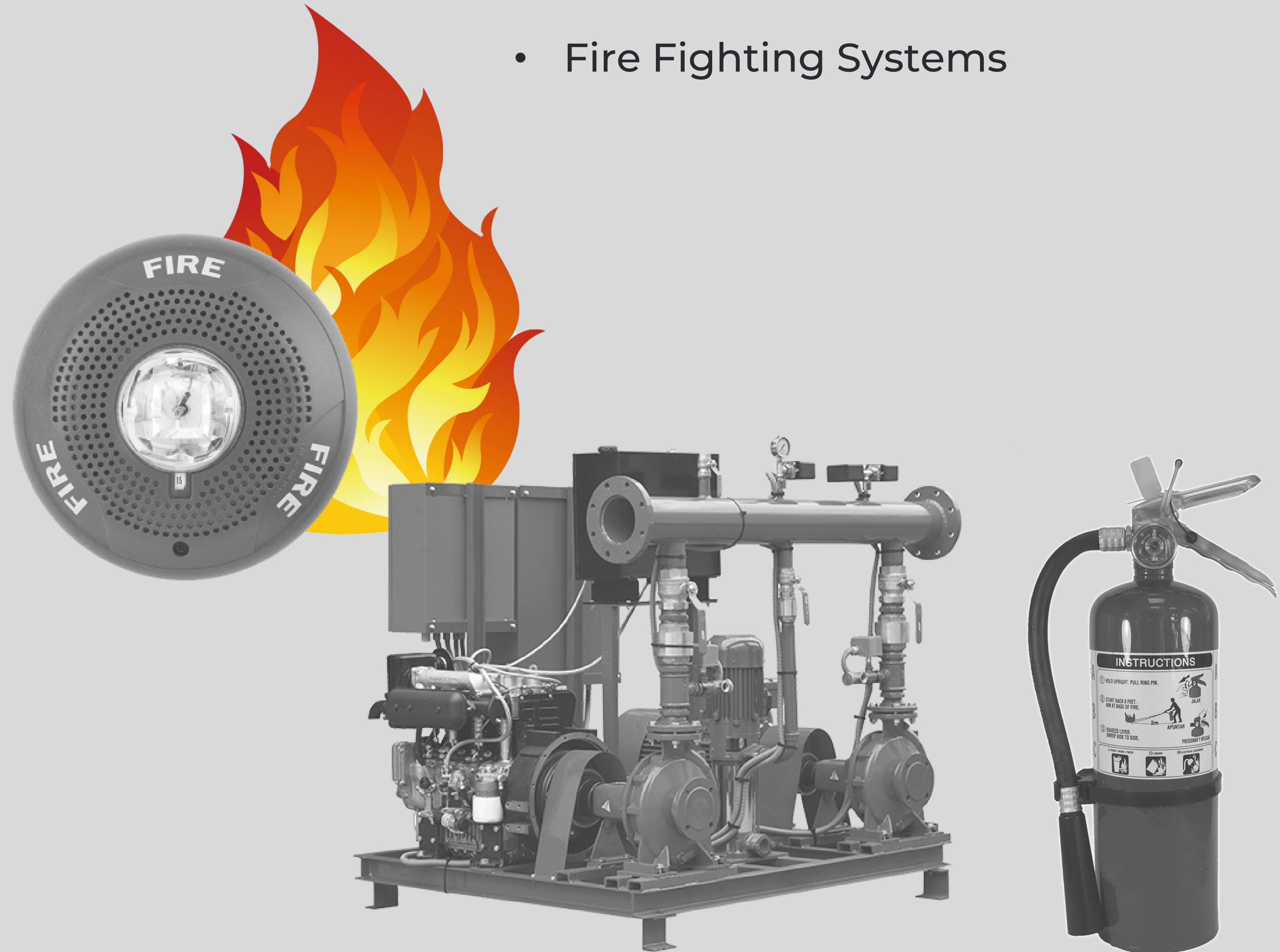

Emergency Lightings





CCTV



Intruder Detection



Access Control System

Mechanical, Electrical and Plumbing (MEP) Systems

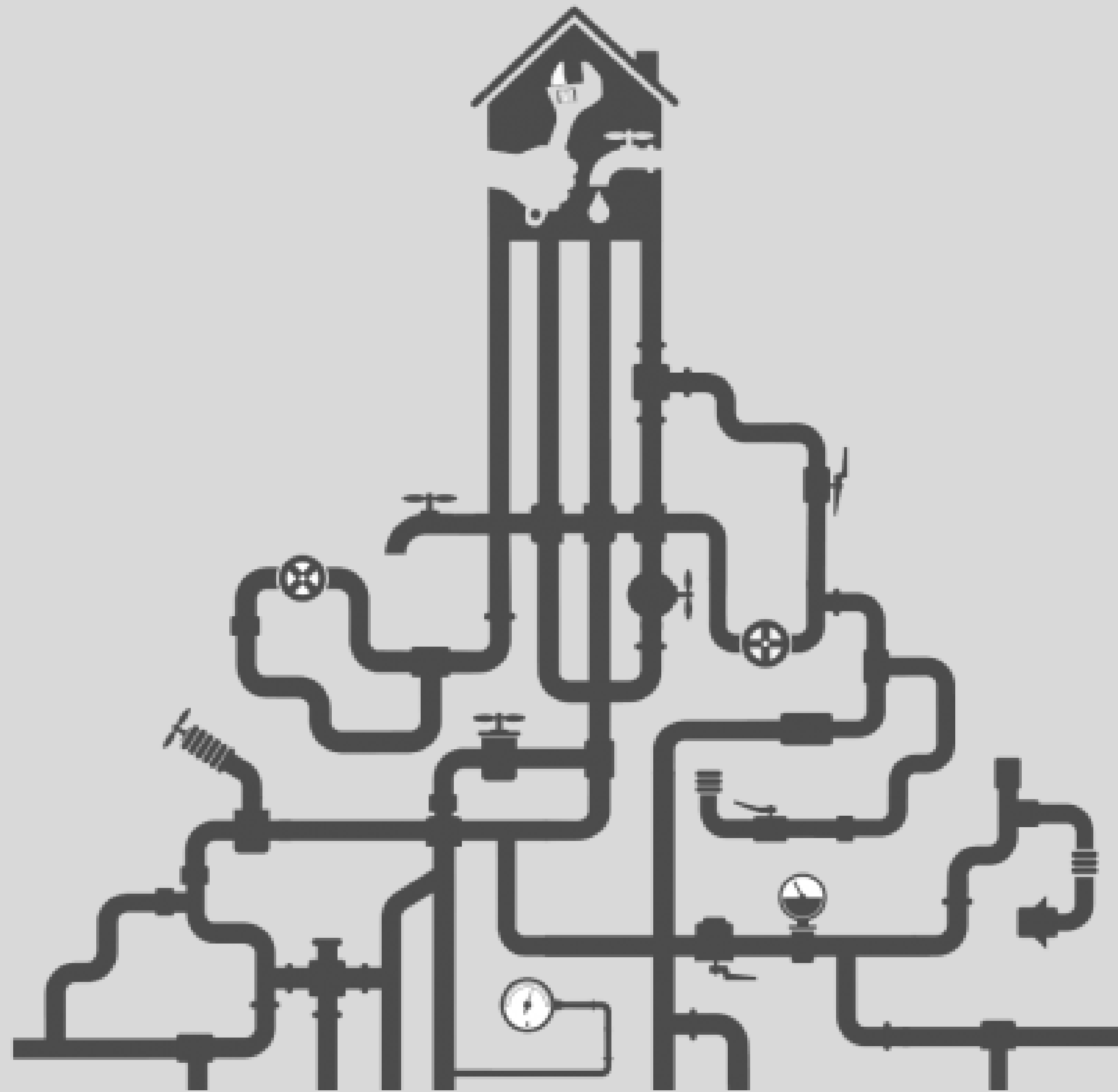

- Mechanical systems
- Electrical systems
- Plumbing systems



Mechanical systems

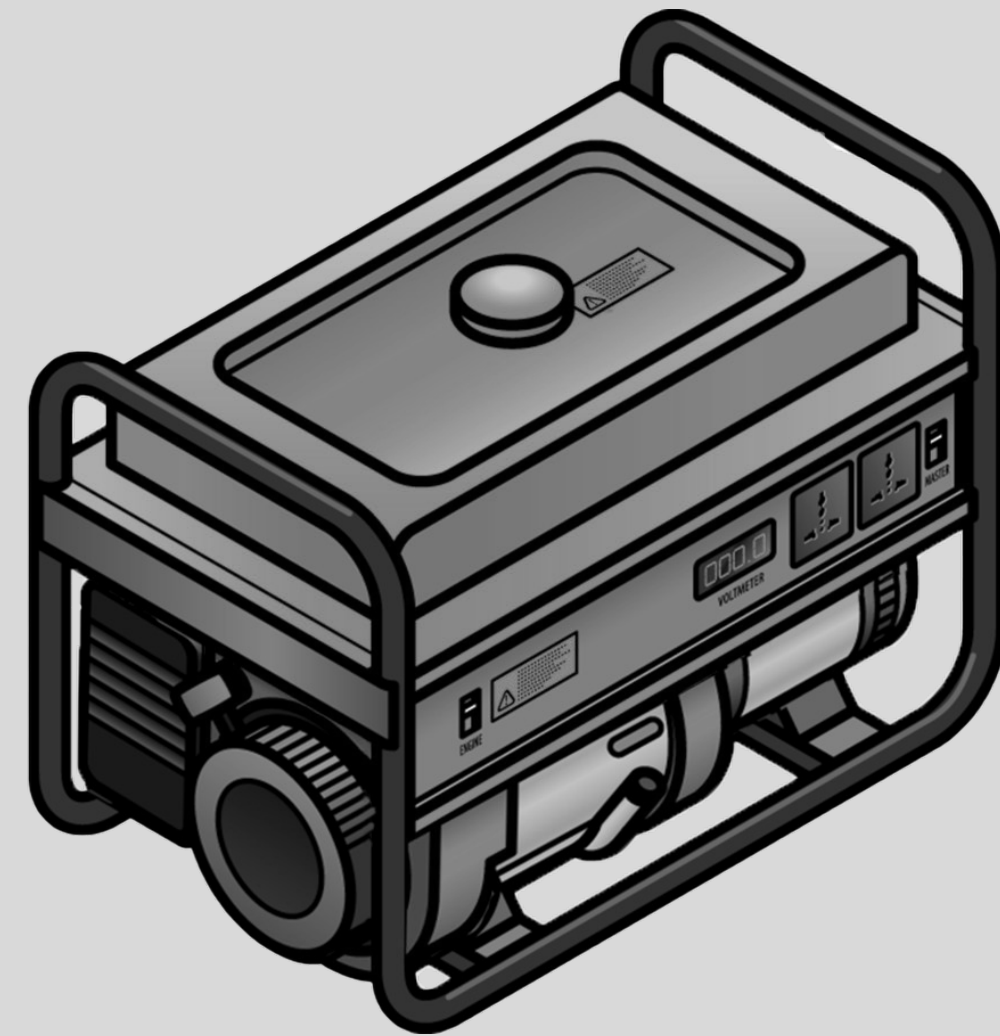

Electrical systems (Electric power system)



Energy system (electrification system)

- | | |
|----------------|-----------------------|
| 1 Pole | 5 Drive mechanism |
| 2 Cantilever | 6 Section insulator |
| 3 Catenary | 7 Composite insulator |
| 4 Disconnecter | 8 Feeder line |

- overhead lines
- Other components

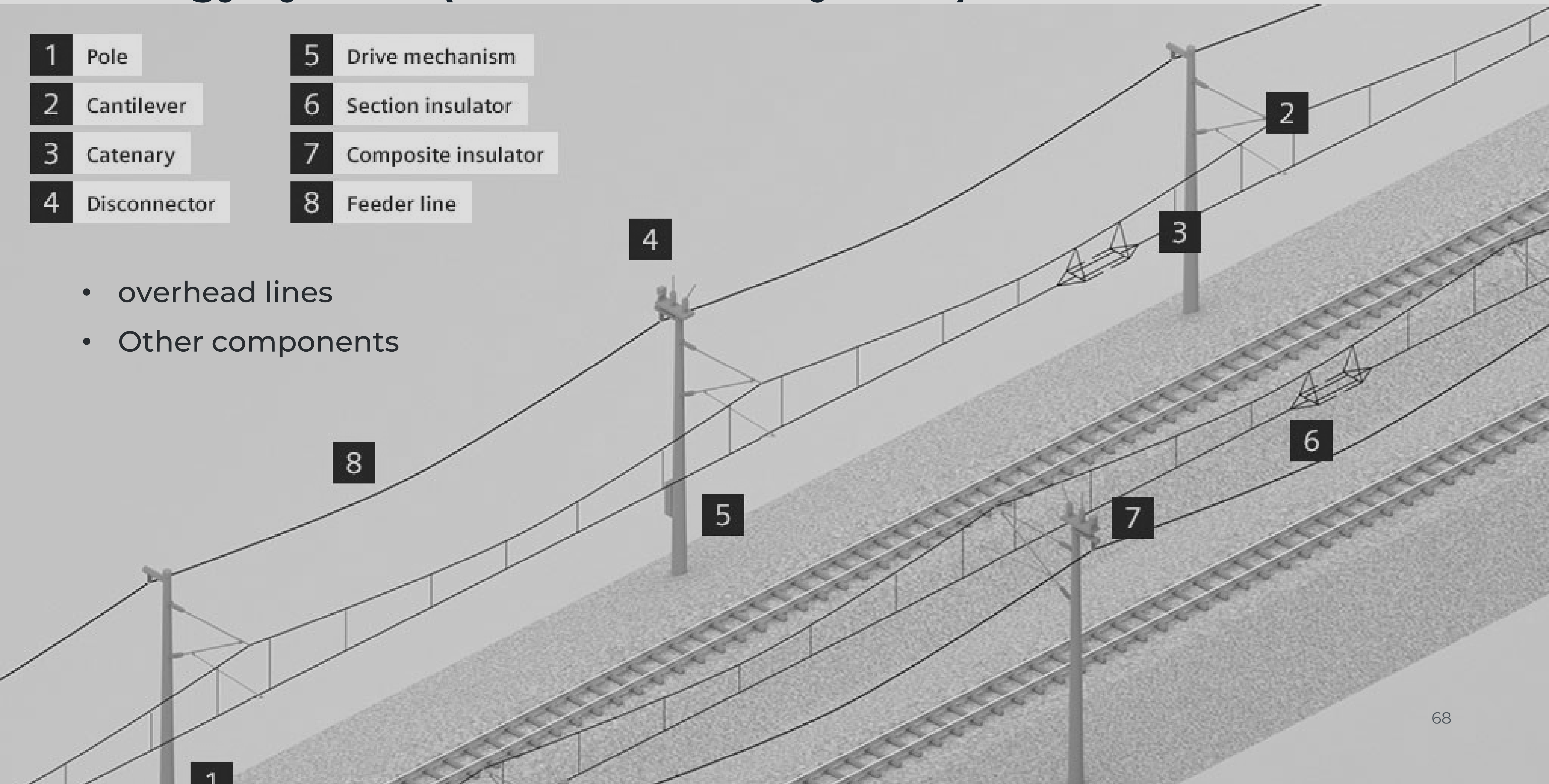

A high-speed train is shown in motion, traveling from left to right across the bottom of the frame. The train is white with dark accents and is set against a background of a city skyline with various skyscrapers. A large, semi-transparent magnifying glass graphic is positioned over the top left of the image, with its handle extending towards the right. The text 'Rolling Stock Provider's' is written inside the magnifying glass's lens.

**Rolling
Stock
Provider's**

point of view

Railway Rolling Stock

Rolling stock comprises all the vehicles that move on a railway. Trains (or rolling stock) consist of two types of vehicle:

- a locomotive or power-car that enables the train to move, and
- Coaches/wagons
 - passenger coaches that carry passengers
 - freight wagons that carry goods (freight).

- A typical vehicle consists of a car body and bogies

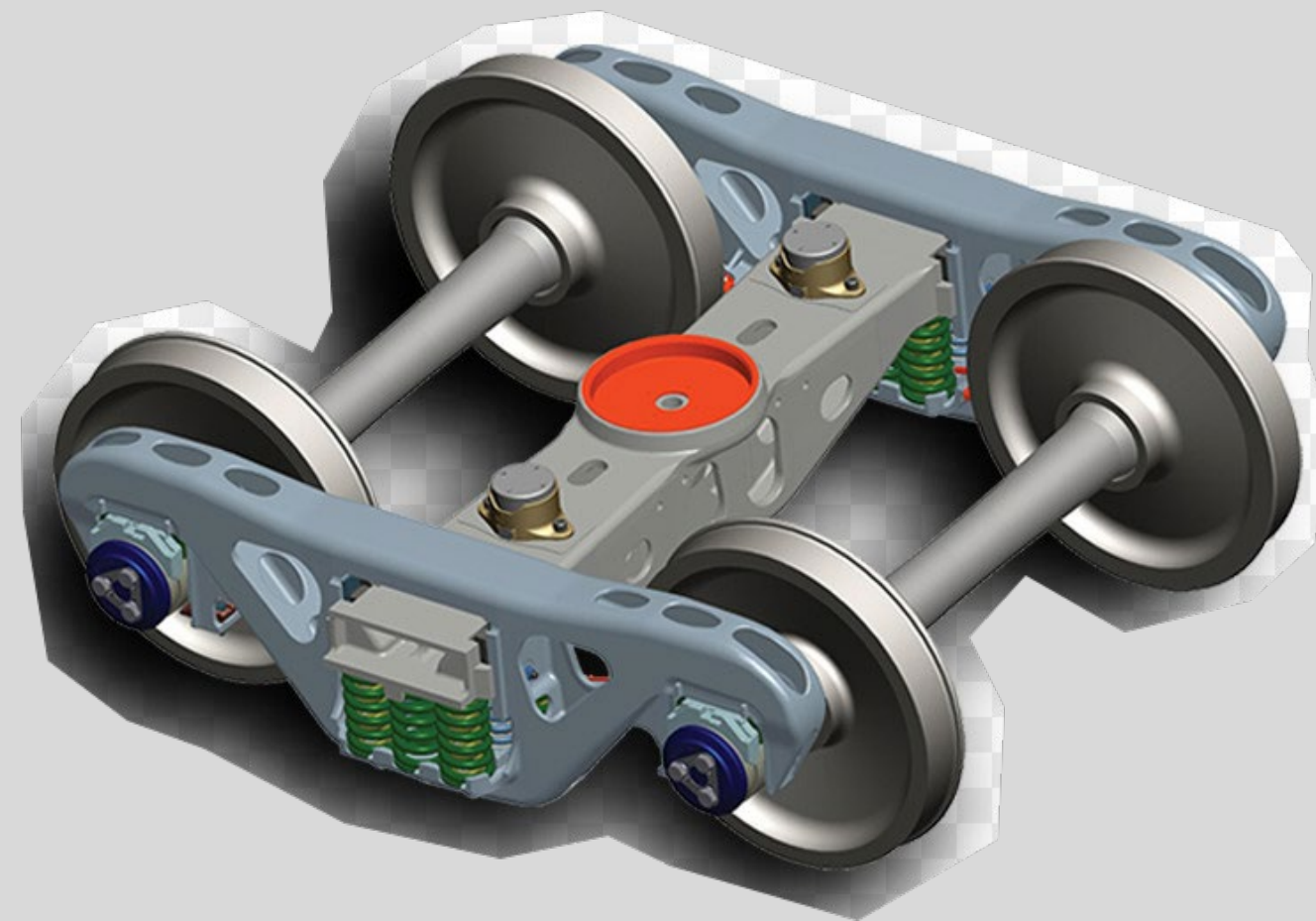
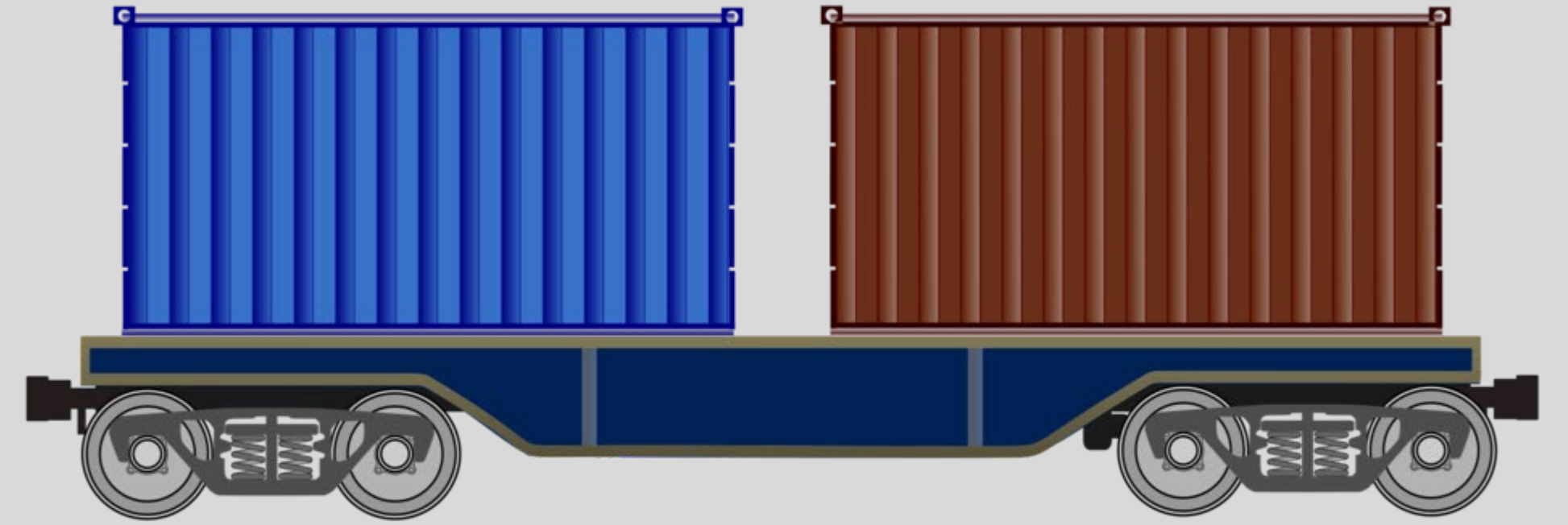

Locomotives



Passenger locomotive



Freight locomotive



Shunting locomotive

Multiple Units



Passenger Coaches



Freight Wagons



Fitting Platform is a wagon used for transportation of machines, equipment, long cargoes, containers, as well as bulk cargoes that do not require protection from atmospheric precipitation.



sliding wall wagon, a present-day standard for palletised goods with lockable/movable partitions

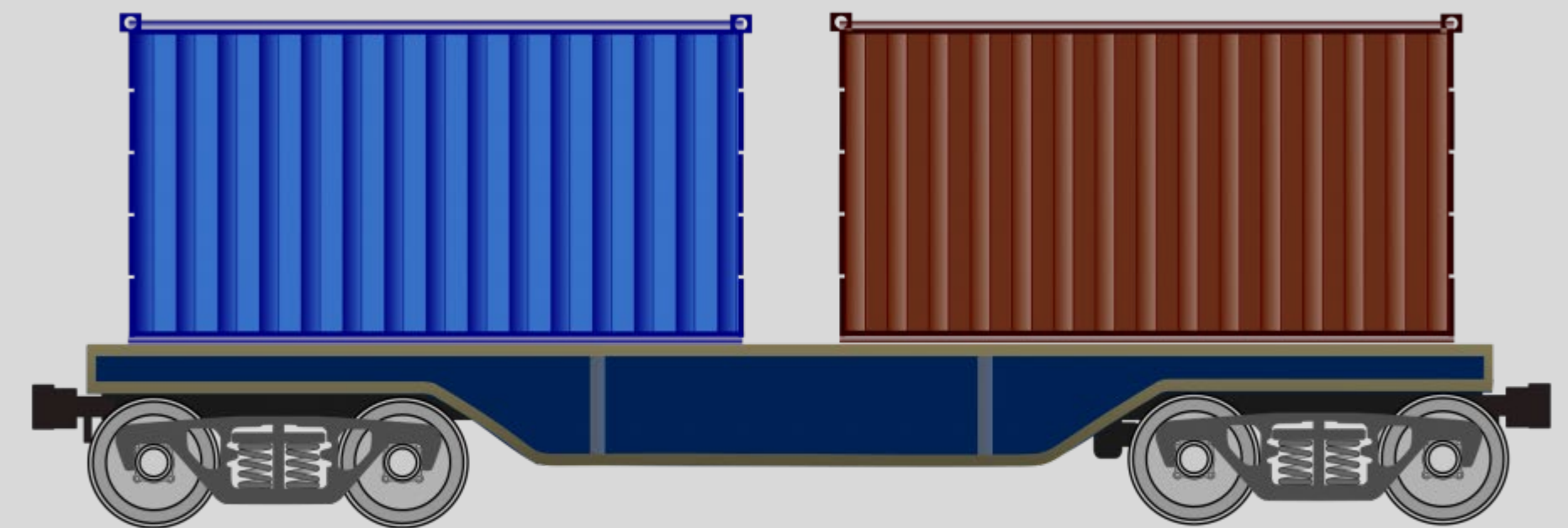

Container platforms do not have sides and are equipped with special locks for fastening of heavy-duty universal containers of any types.



Hopper is a kind of wagon used for the mass transportation of fertilizers, cement, grain and other bulk cargo.

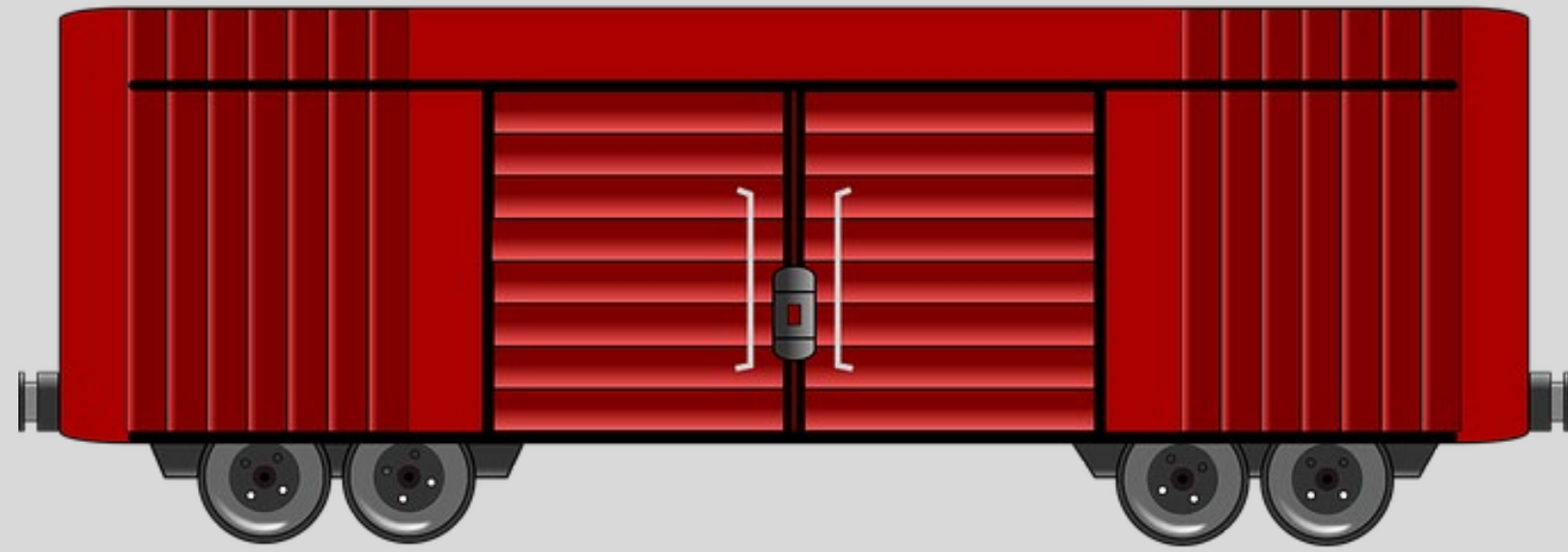

Covered freight wagon is used to transport cargoes that require protection from atmospheric precipitation (US/Canada: boxcars)



Semi wagon is designed for the transport of goods that do not require protection from atmospheric precipitation. Semi wagons do not have a roof.

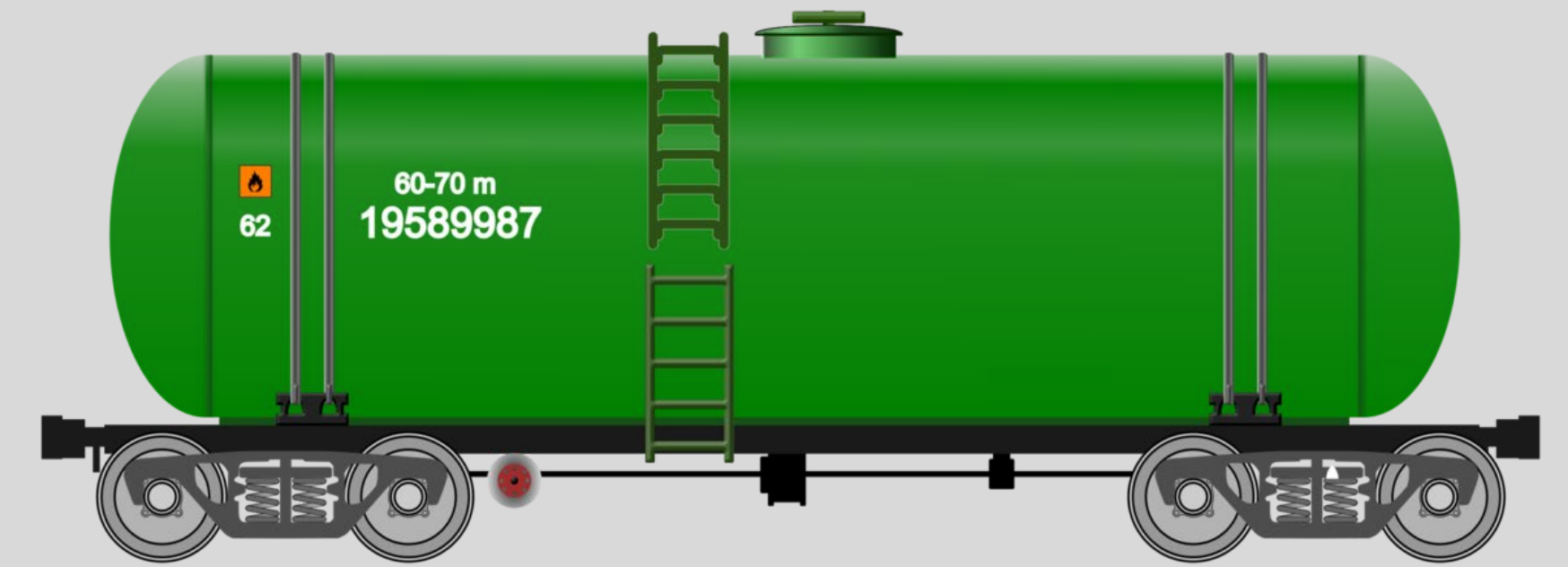

Tank wagon is used for transportation of liquid cargo, liquefied gases and powdered materials.

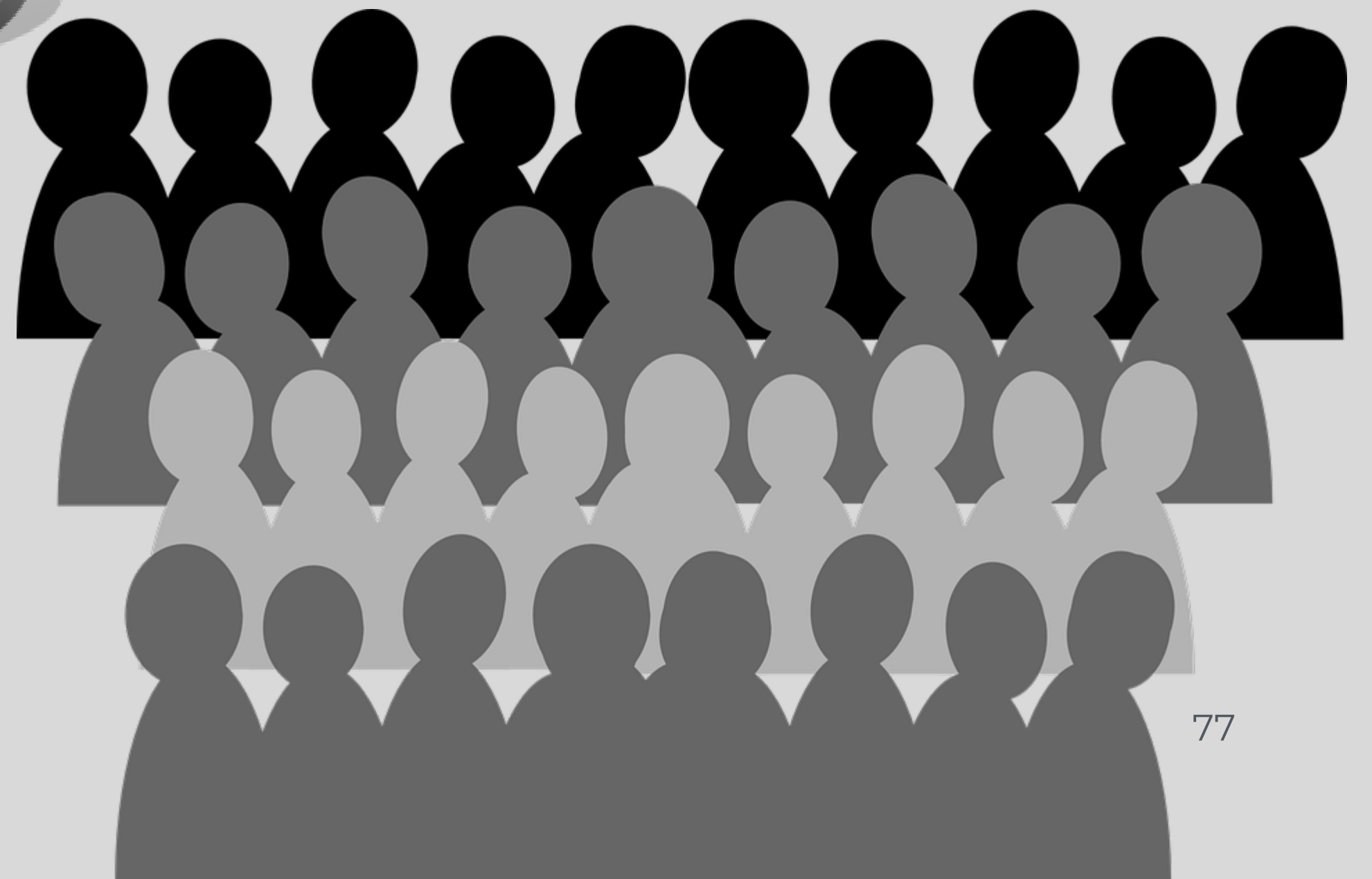



Global warming and the greenhouse effect

CO₂ emissions and Transport

- The transport sector is a key source of air pollution.
- Is responsible e.g. for 30% of total CO₂ emissions in Europe
- The CO₂ emissions are now 25% higher compared to 1990.



The external cost of transport



What is included in the external cost of transport?

Main factors for the external costs of transport:

- Accidents
- Congestion
- Environmental pollution
- Noise
- Climate change

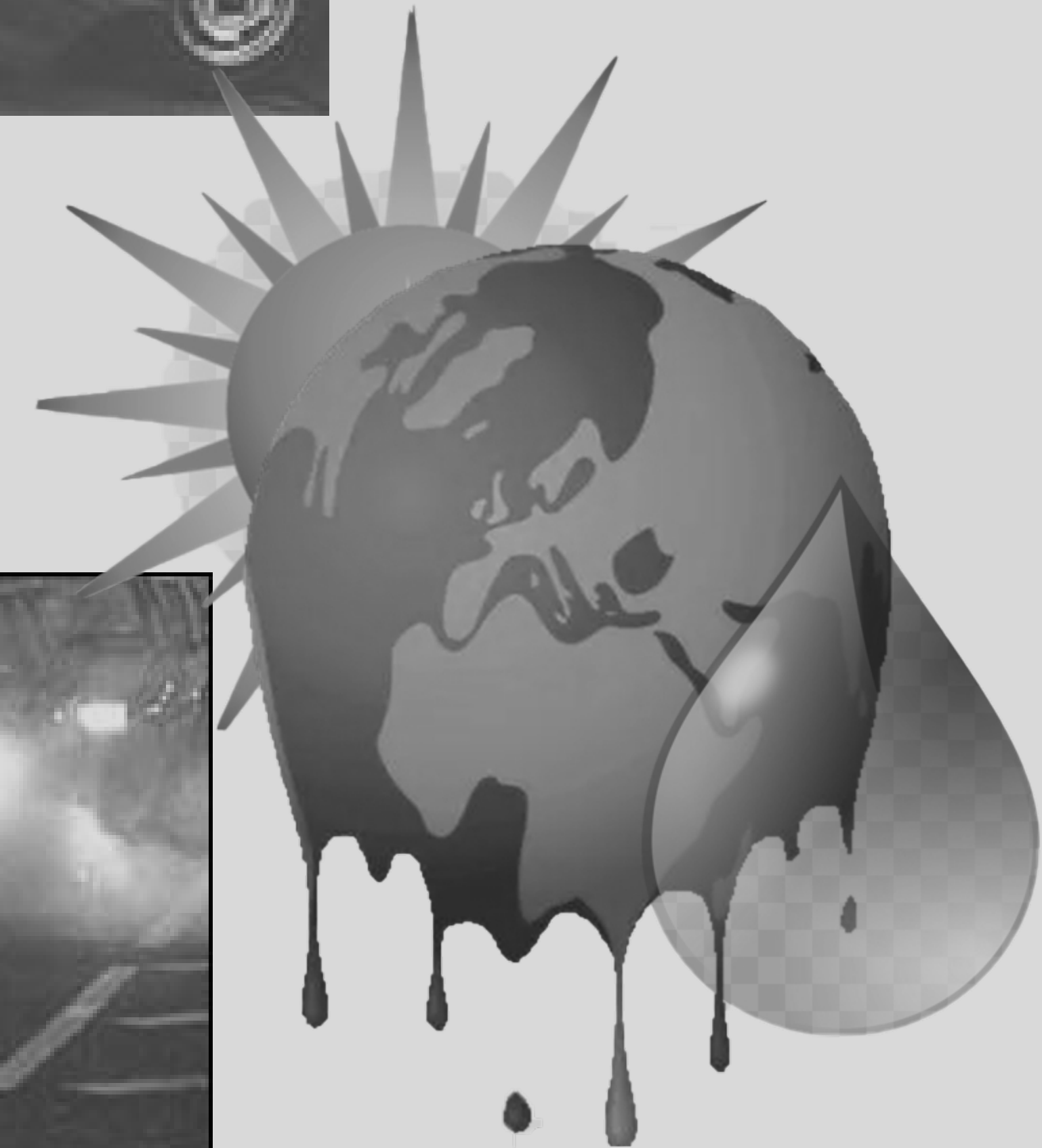

Average external costs for EU-27: passenger transport (excluding congestion)

Source: External Costs of Transport in Europe, Update Study for 2008, 09/2011

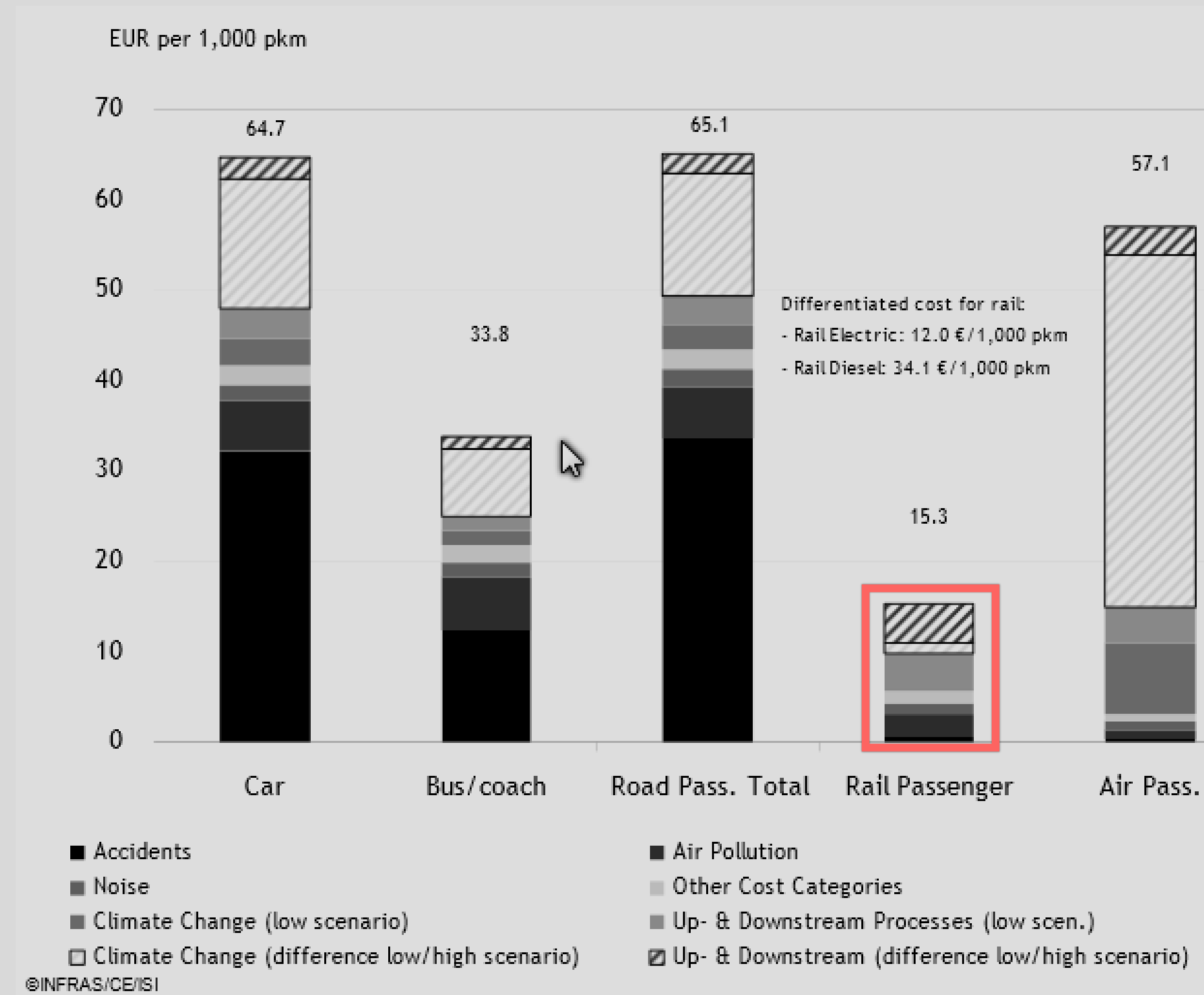

Average external costs for EU-27: freight transport (excluding congestion)

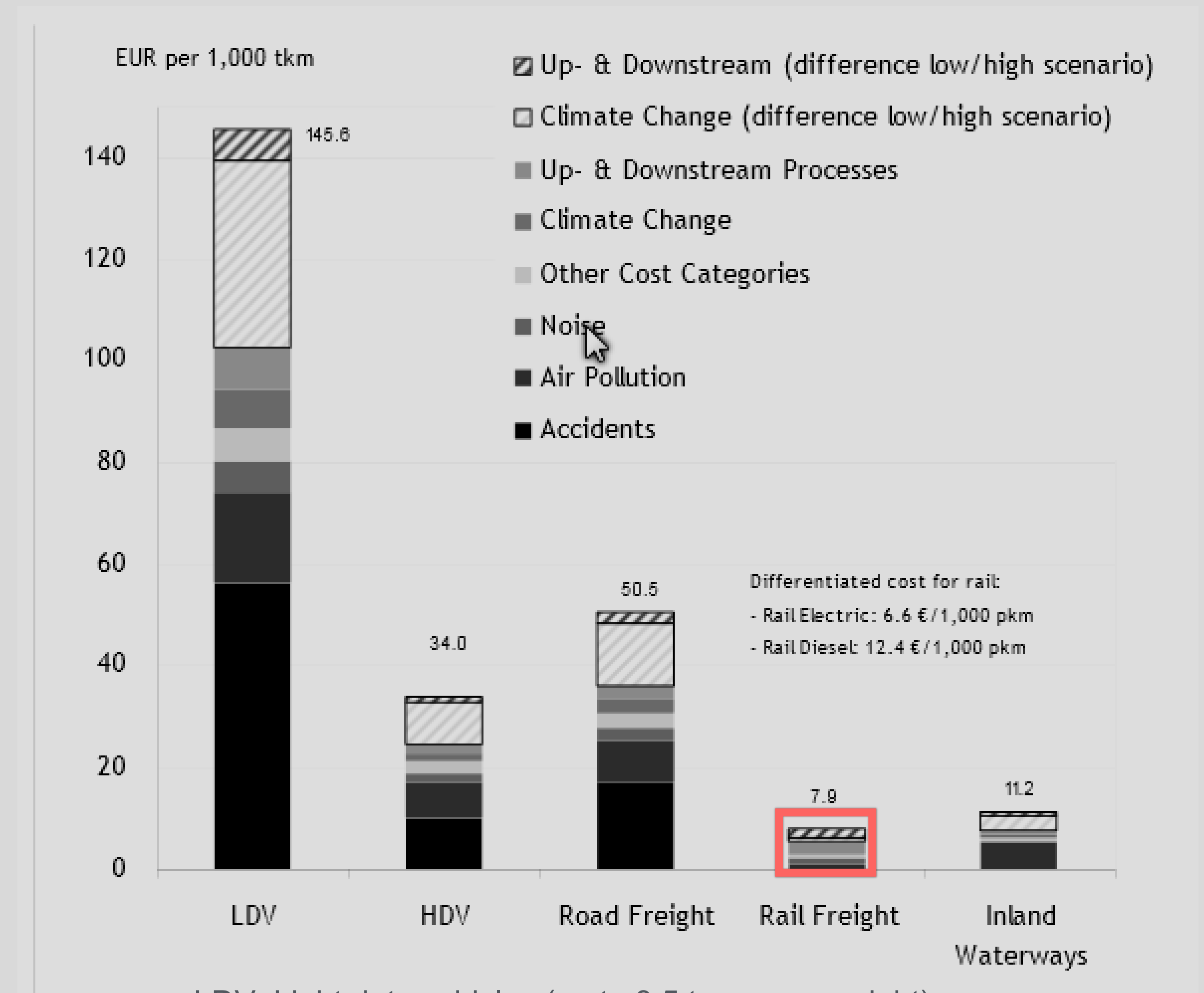

LDV: Light duty vehicles (up to 3.5 ton gross weight)
MC

We behave as if
we had four
planets Earth

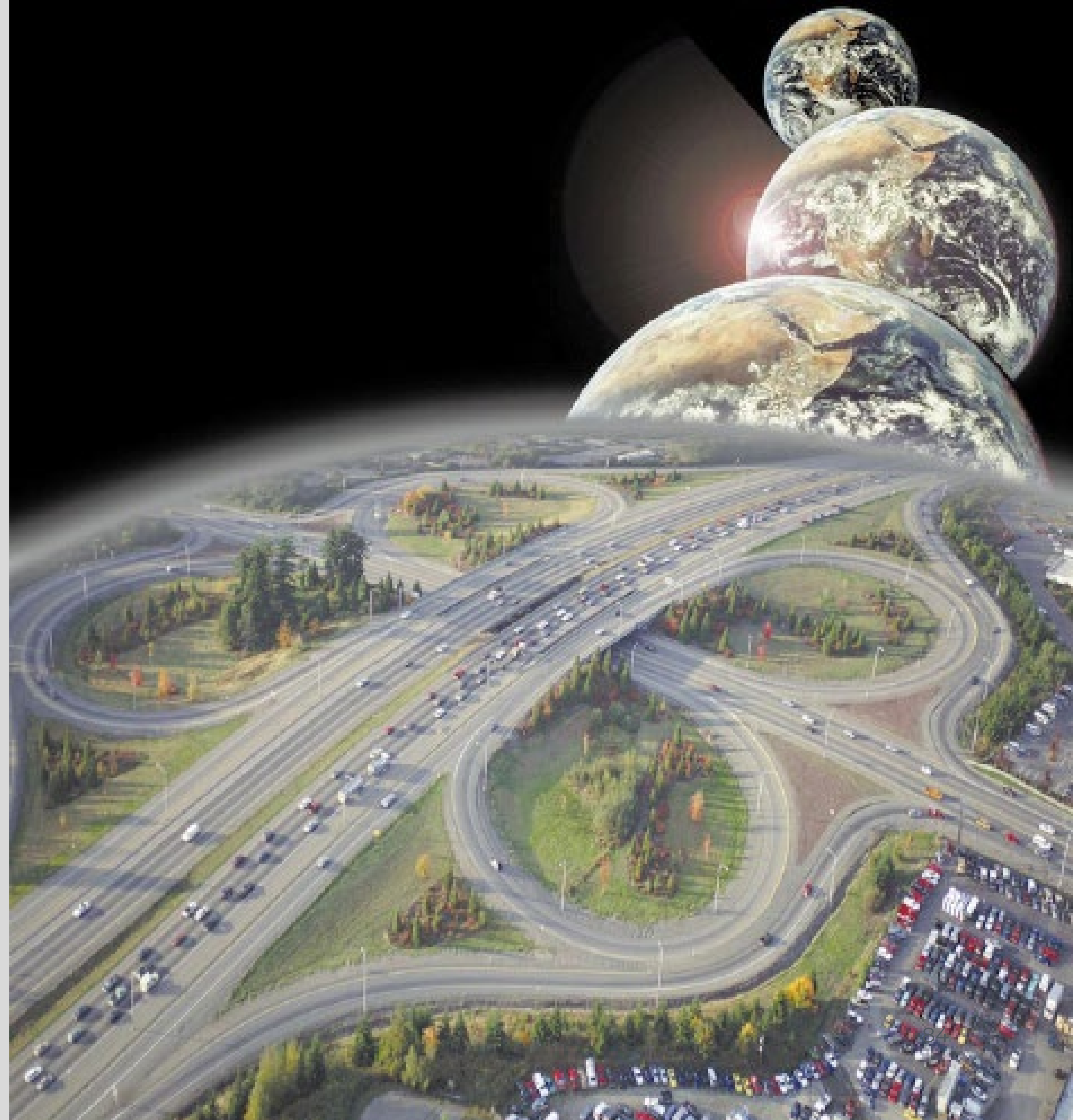



The rail sector has strong advantages when considering the wider social and environmental impacts of different transport modes.

The future railway

Future of Rail 2050

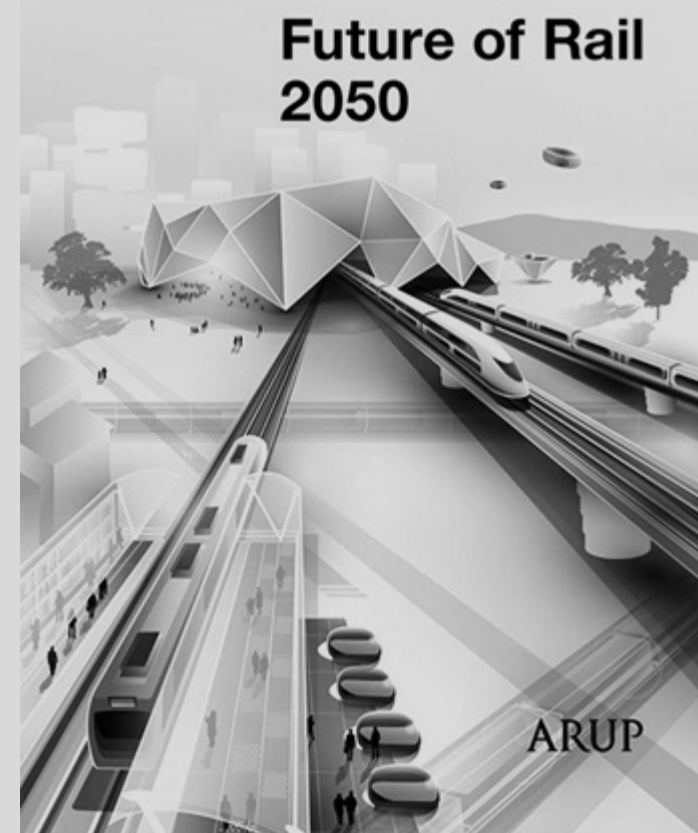
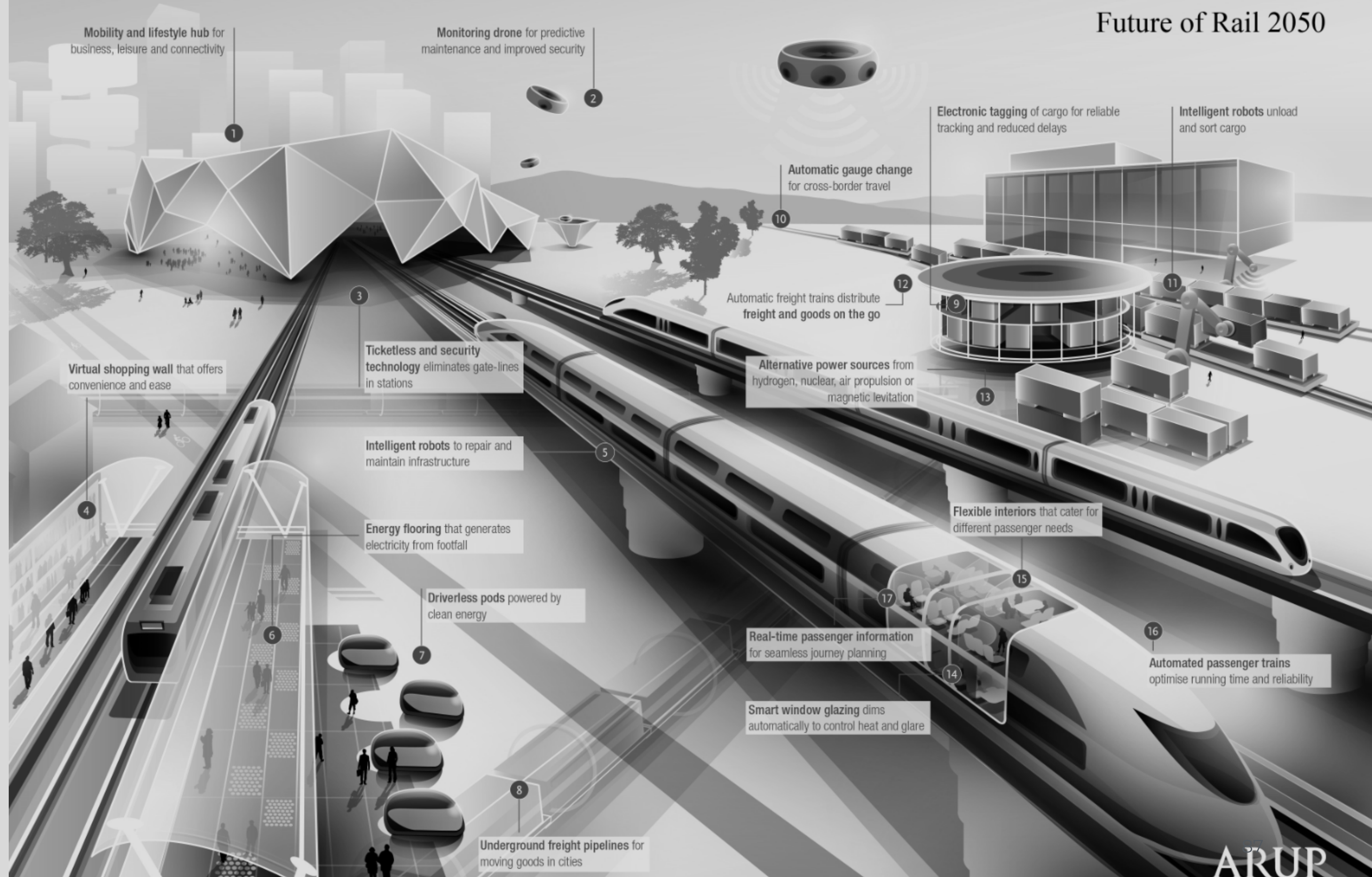

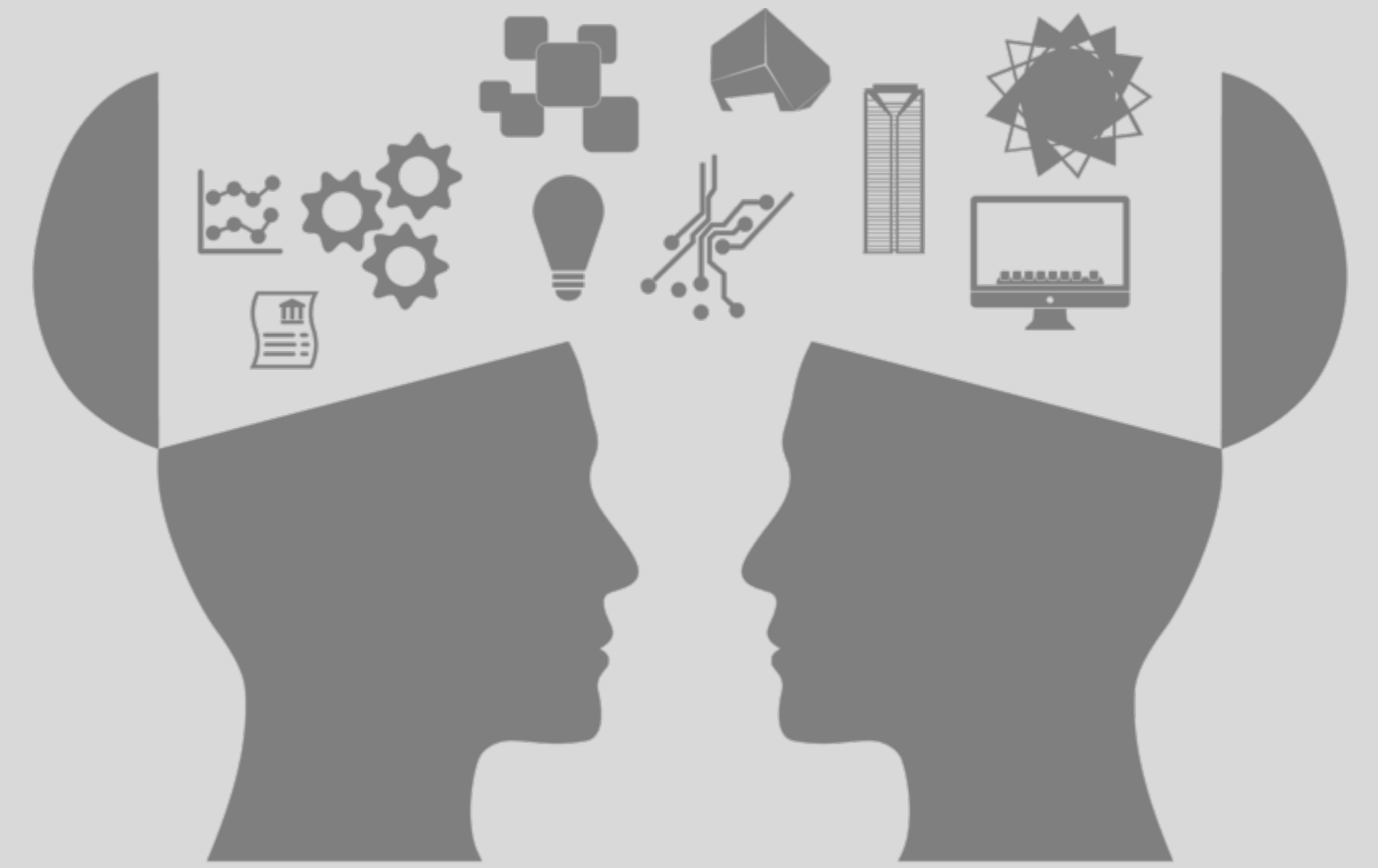

New innovative technologies

Hyperloop

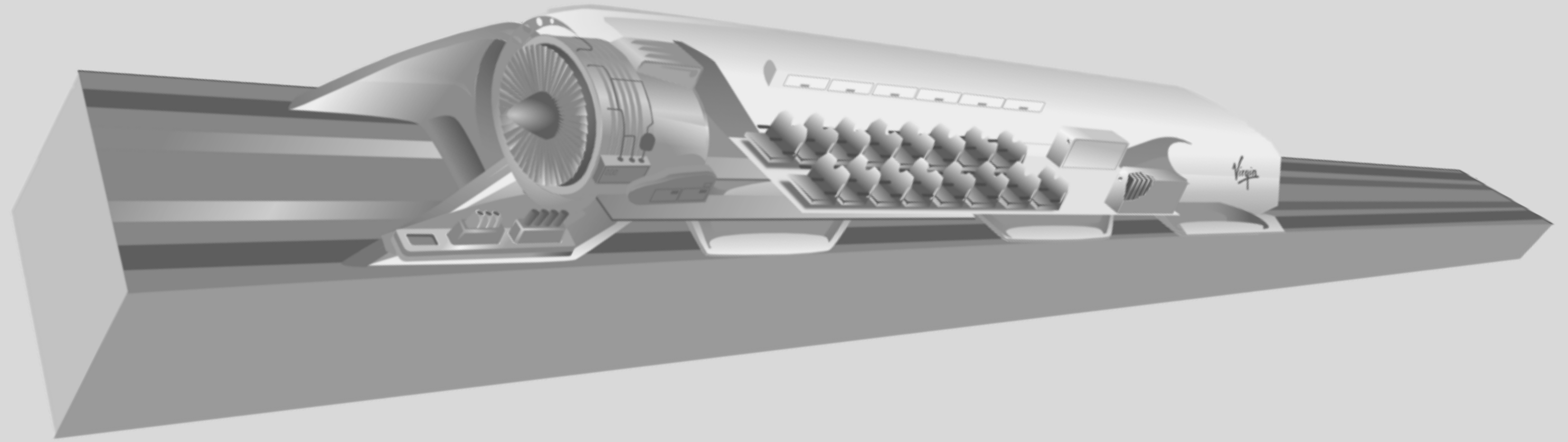

[VIDEO](#)

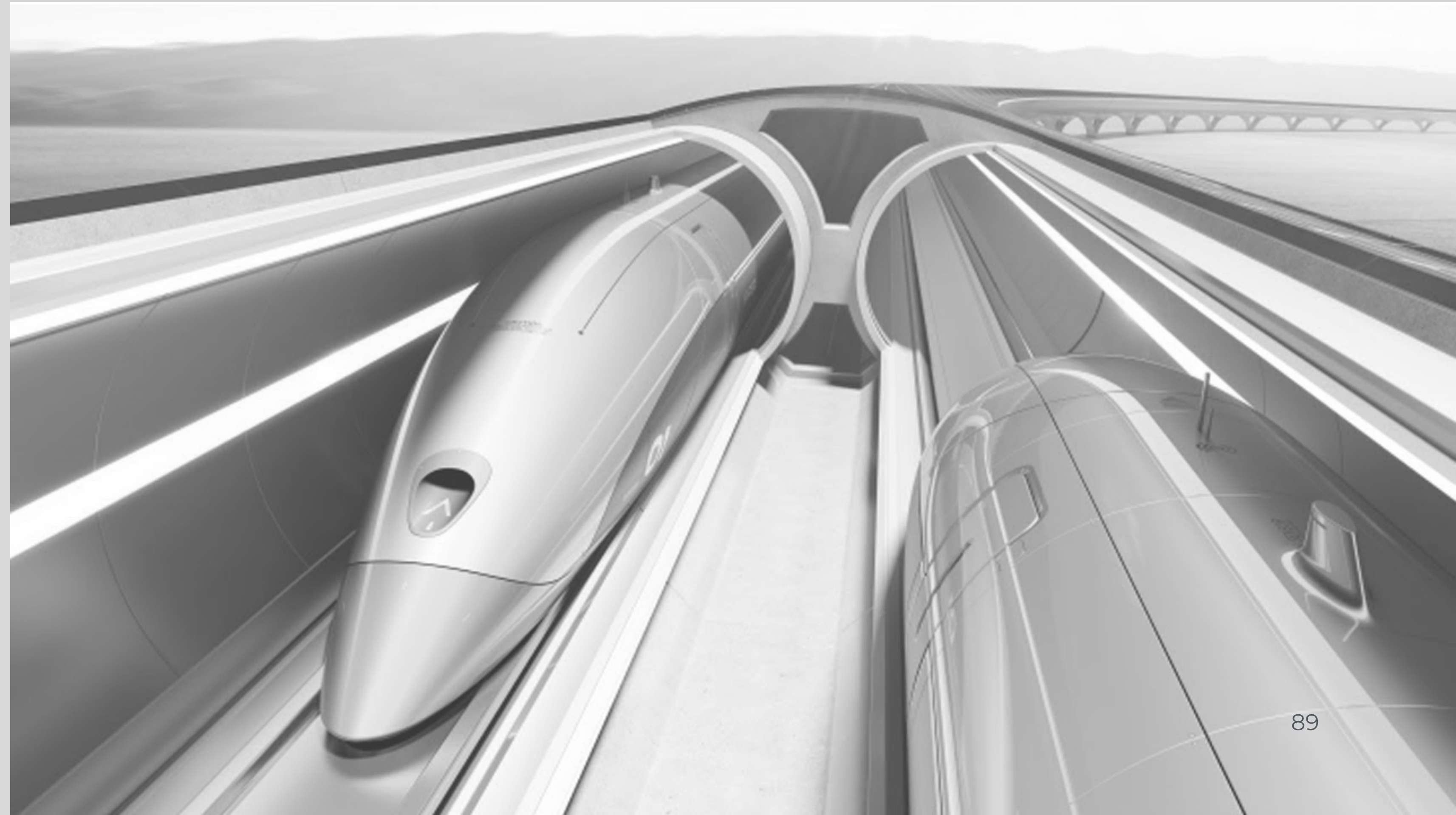

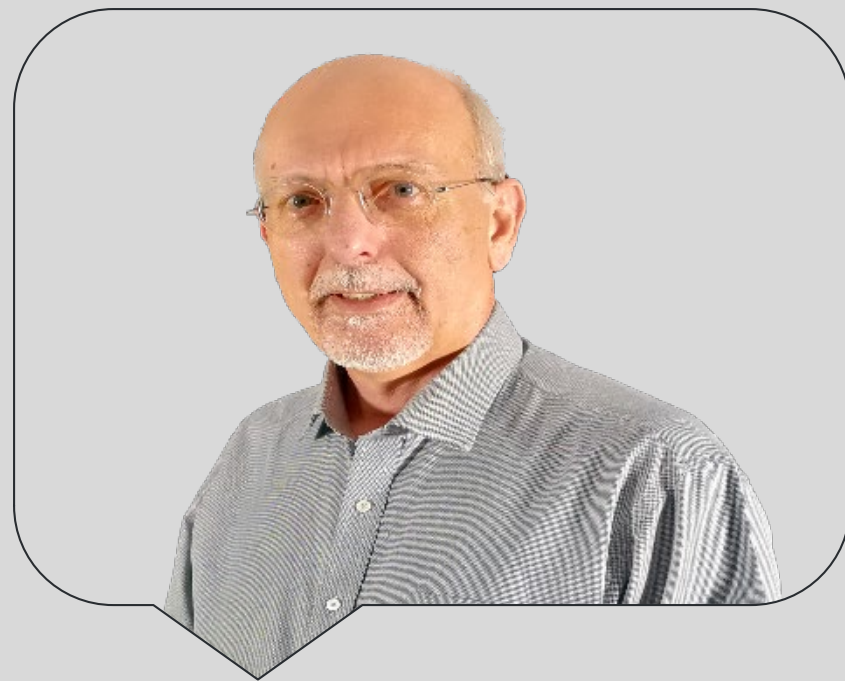

I would like to thank you for your attention!

Visit my website www.railhow.com, the touchstone for people who are working within the engineering sector and would like to progress their careers by gaining practical, yet impactful knowledge and learning experiences.

A few words about me....



- Civil Engineer (MSc.) - University of Hannover in Germany
- Master Executive MBA degree - Athens University of Economics & Business.
- Over 30 years of experience in the railway sector, including eight years in Director positions at Greek Railways Organization
- 2006 - 2013 the Head of the Railway Systems Directorate.
- 2013, 2014 development of the Omani National Railway Network.
- Senior Railway Expert at the Ministry of Transport and Communications in Oman.

Contact US

www.railhow.com

info@railhow.com

Leading a dynamic railway experience!

 **RAILHOW**



Just sit and relax in the train!

Let the train take the strain!